

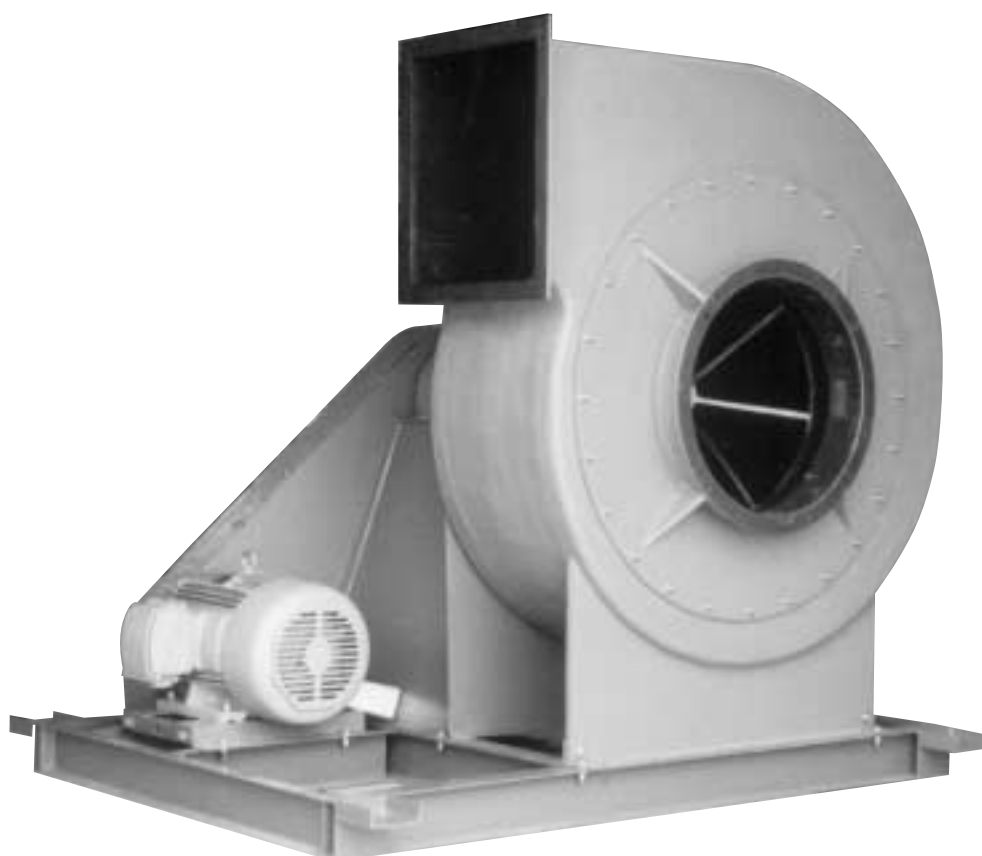

FIBERGLASS RADIAL BLADE CENTRIFUGAL FANS

Type RBF



Model RBF Fiberglass Centrifugal Fans

Advantages of Fiberglass Fans

- Superior corrosion resistance to gases, fumes and vapors.
- Lower maintenance costs.
- More economical than stainless steel construction.
- Lighter weight than steel.

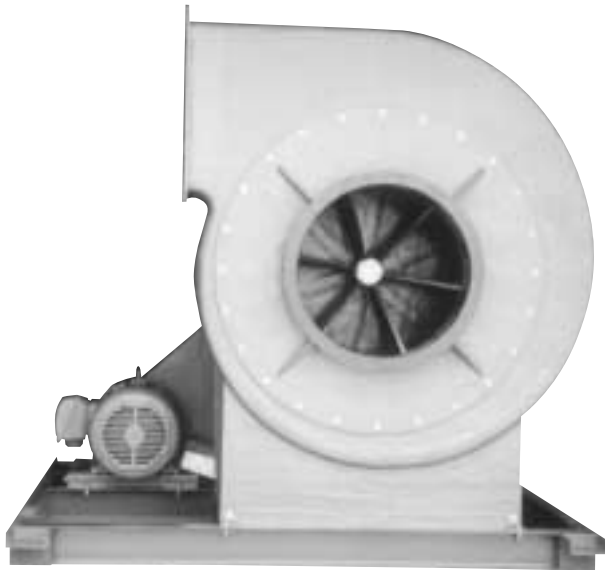

Wheel Design

The RBF wheel features a radial blade design. All wheels are constructed of solid FRP with a steel hub embedded and encapsulated into the backplate.

Contents

Drive Arrangements3
Accessories3
Optional Construction3
Corrosion Resistance Guide4
Temperature & Altitude Correction5
Performance Data6
Dimensional Data20
Typical Specifications22

Construction

Corrosion Resistance

Fan housings are solid FRP hand lay-up construction utilizing corrosion grade flame retardant vinyl ester resin. A glass veil is standard for airstream surfaces providing a resin rich liner to maximize chemical resistance (see Corrosion Resistance Guide on page 4).

Wheel/Shaft Assembly

The fan wheel is attached to a 316 SS stepped shaft using a 316 SS retaining plate. The retaining plate is encapsulated in FRP following assembly.

Flanged Outlet

Integral flanged outlet with drilled bolt pattern is standard.

Inlet Connection

Slip-type connection is standard.

Aerovent certifies that the Fiberglass Centrifugal Fans shown on pages 6 through 19 have been tested and rated in accordance with industry accepted test codes, and are guaranteed by the manufacturer to deliver rated performance.

Drive Arrangements

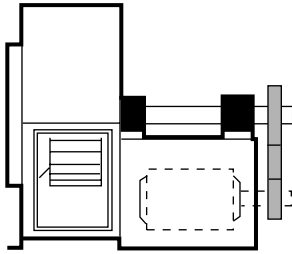

Arrangement 10

V-belt drive with the motor mounted directly under the fan shaft on a slide rail base. This provides for easy adjustment of the belt tension. Maximum temperature is 200°F.

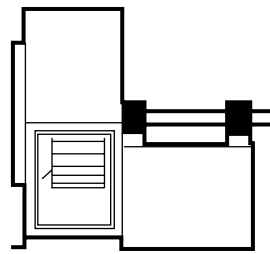

Arrangement 1

Shaft and bearing assembly designed to be driven by a separately mounted motor. Maximum temperature is 200°F.

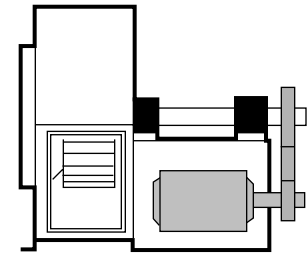

Arrangement 9

Motor is mounted on the bearing base support. A slide rail base under the motor adjusts for belt tension. Motor is located on the right side as standard (when viewed from the drive end of shaft). Maximum temperature is 200°F.

Accessories

Bolted Inspection Door — Limited access panel bolted and sealed to the housing.

Weather Cover (Arr. 10) — For complete protection of shaft, bearings, motor and drive from weather.

OSHA Type Belt Guard (Arr. 1 & 9) — Provides maximum protection for all personnel and complete coverage of belts and sheaves. Includes a tachometer opening for checking the fan speed.

Shaft & Bearing Guard — Solid sheetmetal enclosure designed to cover the shaft and bearings. Grease lines are accessible for lubrication purposes.

Flanged Inlet — Heavy fiberglass flange; drilling standard.

Unitary Base (Arr. 1) — Unitary bases offered in sizes 15 – 57.

Vibration Isolation — Rubber-in-shear or spring isolators available for all sizes and arrangements.

Housing Drain — Provided with female pipe thread at low point of scroll.

Shaft Seal — A heavy Teflon seal is standard to minimize housing leakage.

Optional Construction

Optional Materials

- 304 SS or 316 SS bearing pedestals and inlet supports.
- Synthetic surfacing veil.
- Special resins to suit specific applications.
- Fire Retardant Resin — Reduces the resin's tendency to burn. Antimony trioxide is included to attain a flame spread rating of 25 or less.

Spark Resistant Construction

Spark resistant construction for fiberglass fans is recommended when the fan is handling explosive fumes. Although fiberglass is a non-sparking material, it can build and retain a static charge that can be potentially hazardous. With spark resistant construction, the fan is statically grounded by carbon impregnation to reduce a static charge buildup.

Corrosion Resistance Guide

The following table lists gases, fumes, and vapors that are commonly exhausted from chemical processes. Using the "Legend of Symbols," the table indicates how Aerovent's standard fiberglass fans will withstand exhausting the particular gas, fume, or vapor.

This data is based on a maximum temperature of 200°F (93°C).

Legend of Symbols

- S — Satisfactory Application
- L — Limited Life or Life Tests Incomplete
- U — Unsatisfactory

APPLICATION	SATURATED VAPOR	DRY VAPOR	EXCESS DRY AIR	APPLICATION	SATURATED VAPOR	DRY VAPOR	EXCESS DRY AIR
ACIDS				ALKALINE SALTS			
Acetic	L	S	S	Sodium Bicarbonate	L	S	S
Aqua Regia	U	U	L	Sodium Carbonate	L	S	S
Boric	S	S	S	Sodium Chloride	L	S	S
Butyric	S	S	S	Sodium Cyanide	L	S	S
Carbonic	S	S	S	Trisodium, Phosphate	L	L	S
Chromic	S	S	S	ALKALIS			
Citric	S	S	S	Ammonium Hydroxide	U	L	S
Formic	L	S	S	Calcium Hydroxide	U	L	S
Hydrochloric	S	S	S	Potassium Hydroxide	U	L	S
Hydrocyanic	L	S	S	Sodium Hydroxide	U	L	S
*Hydrofluoric	L	S	S	Sodium Hypochlorite	U	L	S
Hypochlorous	L	S	S	KETONES			
Lactic	S	S	S	Acetone	U	L	S
Maleic	S	S	S	Methyl Ethyl Ketone	U	U	L
Nitric	L	S	S	Methyl Isobutyl Ketone	U	U	L
Oleic	S	S	S	ESTERS			
Oxalic	S	S	S	Butyl Acetate	U	L	S
Perchloric	U	U	U	Ethyl Acetate	U	U	S
Phosphoric	S	S	S	Zinc Acetate	S	S	S
Picric	L	S	S	GASES			
Stearic	S	S	S	Ammonia	L	S	S
Sulfuric	S	S	S	Bromine	U	U	U
Sulfurous	S	S	S	Carbon Dioxide	S	S	S
Tannic	S	S	S	Carbon Disulfide	L	L	S
Tartaric	S	S	S	Chlorine	L	S	S
SALTS, ACID & NEUTRAL				*Fluorine	L	S	S
Alum	S	S	S	*Hydrogen Fluoride	L	S	S
Aluminum Chloride	S	S	S	Hydrogen Sulfide	S	S	S
Aluminum Sulphate	S	S	S	Sulfur Dioxide	S	S	S
Ammonium Chloride	S	S	S	HYDROCARBONS			
Ammonium Nitrate	S	S	S	Benzene	U	U	U
Ammonium Sulphate	S	S	S	Fuel Oil	S	S	S
Calcium Chloride	S	S	S	Gasoline	S	S	S
Calcium Sulphate	S	S	S	Kerosene	S	S	S
Copper Chloride	S	S	S	Lubricating Oil	S	S	S
Copper Sulphate	S	S	S	Mineral Oil	S	S	S
Ferric Chloride	S	S	S	Toluene	U	U	U
Ferric Nitrate	S	S	S	Vegetable Oil	S	S	S
Ferric Sulphate	S	S	S	Naphtha	S	S	S
Magnesium Salts	S	S	S	Methane	S	S	S
Nickel Salts	S	S	S	Butane	S	S	S
Potassium Chloride	S	S	S	Propane	S	S	S
Potassium Nitrate	S	S	S	Xylol	S	S	S
Potassium Sulphate	S	S	S	CHLORINATED SOLVENTS			
Sodium Chloride	S	S	S	Carbon Tetrachloride	L	S	S
Sodium Sulphate	S	S	S	Chlorobenzene	U	U	U
Sodium Sulphite	S	S	S	Chloroform	U	U	U
Stannous Chloride	S	S	S	Perchloroethylene	U	U	L
Zinc Chloride	S	S	S	Trichloroethylene	U	U	L
Zinc Sulphate	S	S	S	GLYCOLS			
ALCOHOLS	S	S	S		S	S	S

*Synthetic Surfacing Veil Required

Performance Correction for Temperature & Altitude

The performance tables in this bulletin are based on standard air conditions of 70°F at sea level (0.075 lbs./cu.ft. density). If the performance of the fan is based on standard conditions, the fan can be selected directly from the performance tables in this catalog.

When a fan operates at temperatures other than 70°F or altitudes other than sea level, a “temperature and altitude density ratio” (Table 1) is used to convert these conditions to standard air conditions. This conversion must be done before the fan can be selected from the performance tables in this catalog. After the fan is selected at standard conditions, the temperature correction ratio must be used to convert the brake horsepower at standard air conditions to the brake horsepower at operating conditions. This is shown in the example below.

Example: Specifications are for a 29" FRP fan to provide 3,200 CFM at 5" SP at 150°F at 1,000 ft. elevation (0.0628 lbs./cu. ft. density).

For 150°F and 1,000 ft. elevation Table 1 shows a density ratio of 0.838. Using the temperature and altitude density ratio, the static pressure at standard conditions is determined as follows:

$$\text{Operating SP} \div \frac{\text{Temp. \& Alt.}}{\text{Density Ratio}} = \text{SP at Std. Conditions}$$

$$5" \text{ SP} \div 0.838 = 6" \text{ SP at Standard Conditions}$$

Turn to page 13 for the Size 29 RBF fan performance table. Using 3,200 CFM at 6" SP at standard conditions, find the RPM and brake horsepower to be 1,120 RPM and 5.07 BHP. **Note:** 5.07 BHP is the brake horsepower required at standard conditions and is also referred to as the “cold brake horsepower” or “starting brake horsepower.”

The actual brake horsepower at the operating condition of 150°F and 1,000 ft. elevation is determined by the following equation:

$$\text{BHP at Std. Conditions} \times \frac{\text{Temp. \& Alt.}}{\text{Density Ratio}} = \text{BHP at Oper. Conditions}$$

$$5.07 \text{ BHP} \times 0.838 = 4.26 \text{ BHP at Operating Conditions}$$

Therefore, the Size 29 RBF fan providing 3,200 CFM at 5" SP at 150°F and 1,000 ft. elevation will run at 1,120 RPM and will require 4.26 BHP at operating conditions and 5.07 BHP at starting. Refer to Table 2 and Table 3 for maximum safe speeds at elevated temperatures.

Maximum Safe Speeds

When operating at temperatures other than 70°F, the maximum speed of the fan is affected. To determine the maximum speed at the operating temperature, a “Maximum Safe Speed Temperature Factor” (Table 3) is applied to the “Maximum Safe Wheel Speed at 70°F” (Table 2).

Table 2.
Maximum Safe Wheel Speed at 70°F

SIZE	RPM	SIZE	RPM
10	4477	29	1935
12	4090	33	1740
13	4100	36	1570
15	3670	40	1435
19	2995	45	1270
22	2535	50	1135
26	2195	57	1000

Table 3.
Maximum Safe Speed Temperature Factors

TEMPERATURE		FACTOR
°F	°C	
70	21	1.00
100	38	1.00
150	66	0.95
200	93	0.90

Example: The maximum safe speed for a Size 29 RBF operating at 150°F is 1,553 RPM. The calculation is shown below.

$$\text{Max. RPM at 70°F (Table 2)} \times \text{Temp. Factor (Table 3)} = \text{Max. RPM at Operating Temp.}$$

$$1,635 \times 0.95 = 1,553 \text{ Max. RPM at 150°F}$$

Since the Max. RPM at 150°F is 1,553, the fan in our previous example running at 1,120 RPM at 150°F would be acceptable.

Table 4. Metric Conversion Factors

DESCRIPTION	ENGLISH UNIT	METRIC UNIT	CONVERSION FACTOR	
			ENGLISH TO METRIC	METRIC TO ENGLISH
VOLUME	CFM	m ³ /s	.000472	2118.90
PRESSURE	ln. w.g.	kPa	.24866	4.02156
POWER	BHP	kW	.74570	1.3410
VELOCITY	fpm	m/s	.00508	196.85
SPEED	RPM	rps	.01667	60.00
AREA	ft ²	m ²	.09290	10.7640
CIRCUMFERENCE	ft	m	.30480	3.2808
DIAMETER	in.	mm	25.400	0.03937

Table 1. Temperature and Altitude Density Ratios

AIR TEMP °F	ALTITUDE IN FEET ABOVE SEA LEVEL											
	0	1000	2000	3000	4000	5000	6000	7000	8000	9000	10000	15000
	BAROMETRIC PRESSURE IN INCHES OF MERCURY											
	29.92	28.86	27.82	26.82	25.84	24.90	23.98	23.09	22.22	21.39	20.58	16.89
-50	1.293	1.247	1.201	1.159	1.116	1.076	1.036	0.997	0.960	0.924	0.889	0.729
0	1.152	1.111	1.071	1.032	0.995	0.959	0.923	0.889	0.856	0.824	0.792	0.650
50	1.039	1.003	0.967	0.932	0.897	0.864	0.833	0.801	0.772	0.743	0.715	0.586
70	1.000	0.964	0.930	0.896	0.864	0.832	0.801	0.772	0.743	0.714	0.688	0.564
100	0.946	0.912	0.880	0.848	0.818	0.787	0.758	0.730	0.703	0.676	0.651	0.534
150	0.869	0.838	0.808	0.770	0.751	0.723	0.696	0.671	0.646	0.620	0.598	0.490
200	0.803	0.774	0.747	0.720	0.694	0.668	0.643	0.620	0.596	0.573	0.552	0.453

Performance Data

RBF 10

Outlet Area = 0.091 Sq. Ft.

Wheel Dia. = 10.625

Tip Speed = 2.782 x RPM

CFM	OV	0.125" SP		0.25" SP		0.375" SP		0.5" SP		0.625" SP		0.75" SP		0.875" SP		1" SP		1.25" SP			
		RPM	BHP	RPM	BHP	RPM	BHP	RPM	BHP	RPM	BHP	RPM	BHP	RPM	BHP	RPM	BHP	RPM	BHP	RPM	BHP
91	1000	638	0.01	778	0.01	896	0.01	997	0.02	1088	0.02	1172	0.03	1250	0.03						
109	1200	712	0.01	833	0.01	946	0.02	1045	0.02	1134	0.03	1215	0.03	1291	0.04						
127	1400	789	0.01	895	0.02	1000	0.02	1096	0.03	1182	0.03	1262	0.04	1336	0.04						
146	1600	870	0.02	973	0.02	1062	0.03	1153	0.03	1237	0.04	1315	0.05	1387	0.05	1456	0.06	1535	0.06	1582	0.07
164	1800	947	0.02	1049	0.03	1130	0.03	1210	0.04	1291	0.05	1367	0.05	1438	0.06	1505	0.07	1577	0.08	1629	0.08
182	2000	1026	0.03	1126	0.04	1205	0.04	1276	0.05	1348	0.06	1422	0.06	1491	0.07	1557	0.08	1611	0.09	1679	0.09
200	2200	1107	0.04	1202	0.04	1282	0.05	1348	0.06	1413	0.07	1479	0.07	1546	0.08	1611	0.09	1666	0.10	1730	0.11
218	2400	1190	0.05	1279	0.05	1358	0.06	1425	0.07	1484	0.08	1543	0.08	1604	0.09	1666	0.10	1729	0.12	1784	0.12
237	2600	1278	0.06	1362	0.07	1439	0.08	1506	0.08	1564	0.09	1619	0.10	1673	0.11	1729	0.12	1789	0.13	1841	0.14
255	2800	1362	0.07	1441	0.08	1515	0.09	1582	0.10	1641	0.11	1694	0.12	1744	0.13	1795	0.13	1848	0.15	1899	0.15
273	3000	1447	0.08	1522	0.10	1593	0.11	1658	0.12	1718	0.13	1770	0.14	1819	0.14	1866	0.15	1911	0.17	1961	0.17
291	3200	1532	0.10	1603	0.11	1671	0.12	1735	0.13	1794	0.15	1847	0.16	1896	0.17	1941	0.18	1989	0.20	2030	0.20
309	3400	1618	0.12	1686	0.13	1750	0.14	1812	0.16	1870	0.17	1924	0.18	1973	0.19	2018	0.20	2065	0.22	2102	0.22
328	3600	1709	0.14	1774	0.15	1835	0.17	1894	0.18	1951	0.19	2004	0.20	2054	0.22	2099	0.23	2146	0.25	2182	0.25
346	3800	1796	0.16	1857	0.18	1916	0.19	1973	0.20	2028	0.22	2081	0.23	2130	0.24	2176	0.26	2225	0.28	2258	0.28
364	4000	1882	0.19	1942	0.20	1998	0.22	2053	0.23	2106	0.25	2157	0.26	2206	0.27	2252	0.29	2300	0.31	2335	0.31
382	4200	1970	0.21	2027	0.23	2081	0.25	2133	0.26	2185	0.28	2235	0.29	2282	0.31	2328	0.32	2376	0.35	2412	0.35
400	4400	2057	0.24	2112	0.26	2164	0.28	2215	0.29	2264	0.31	2313	0.33	2359	0.34	2404	0.36	2450	0.39	2488	0.39
419	4600	2150	0.28	2202	0.30	2253	0.31	2302	0.33	2349	0.35	2396	0.37	2441	0.38	2485	0.40	2530	0.43	2569	0.43
437	4800	2237	0.31	2288	0.33	2337	0.35	2384	0.37	2430	0.39	2475	0.41	2519	0.42	2563	0.44	2608	0.47	2645	0.47
455	5000	2325	0.35	2374	0.37	2421	0.39	2467	0.41	2512	0.43	2555	0.45	2598	0.47	2640	0.48	2682	0.52	2721	0.52
473	5200	2414	0.39	2461	0.41	2506	0.43	2551	0.45	2594	0.47	2636	0.49	2678	0.51	2719	0.53	2760	0.57	2798	0.57
CFM	OV	1.5" SP		1.75" SP		2" SP		2.5" SP		3" SP		3.5" SP		4" SP		4.5" SP		5" SP			
		RPM	BHP	RPM	BHP	RPM	BHP	RPM	BHP	RPM	BHP	RPM	BHP	RPM	BHP	RPM	BHP	RPM	BHP	RPM	BHP
146	1600	1698	0.09	1806	0.10	1908	0.11														
164	1800	1744	0.10	1850	0.11	1950	0.13	2135	0.16	2306	0.19										
182	2000	1791	0.11	1896	0.13	1994	0.14	2176	0.18	2344	0.22	2501	0.25								
200	2200	1841	0.12	1944	0.14	2041	0.16	2221	0.20	2386	0.24	2539	0.28	2685	0.31	2822	0.35				
218	2400	1892	0.14	1994	0.16	2090	0.18	2267	0.22	2430	0.26	2582	0.30	2724	0.34	2860	0.39	2990	0.43		
237	2600	1949	0.16	2048	0.18	2143	0.20	2318	0.24	2479	0.28	2629	0.33	2769	0.37	2903	0.42	3031	0.47		
255	2800	2003	0.17	2102	0.20	2195	0.22	2367	0.26	2527	0.31	2675	0.36	2814	0.40	2946	0.45	3072	0.50		
273	3000	2059	0.19	2156	0.22	2248	0.24	2418	0.29	2576	0.34	2723	0.38	2861	0.43	2991	0.49	3116	0.54		
291	3200	2120	0.22	2212	0.24	2302	0.26	2471	0.31	2626	0.36	2772	0.42	2909	0.47	3038	0.52	3162	0.58		
309	3400	2185	0.24	2271	0.26	2358	0.29	2525	0.34	2678	0.39	2822	0.45	2957	0.50	3086	0.56	3208	0.62		
328	3600	2260	0.27	2339	0.29	2420	0.32	2582	0.37	2735	0.43	2876	0.49	3010	0.54	3137	0.60	3259	0.66		
346	3800	2334	0.30	2408	0.33	2483	0.35	2638	0.41	2789	0.46	2929	0.52	3061	0.58	3187	0.64	3308	0.70		
364	4000	2410	0.34	2481	0.36	2551	0.39	2697	0.44	2843	0.50	2983	0.56	3114	0.62	3238	0.69	3358	0.75		
382	4200	2486	0.37	2556	0.40	2623	0.43	2759	0.48	2899	0.54	3037	0.60	3167	0.67	3290	0.73	3408	0.80		
400	4400	2563	0.41	2632	0.44	2697	0.47	2826	0.52	2958	0.58	3092	0.65	3221	0.72	3344	0.78	3461	0.85		
419	4600	2644	0.46	2713	0.49	2777	0.52	2900	0.57	3024	0.63	3152	0.70	3279	0.77	3401	0.84	3517	0.91		
437	4800	2721	0.50	2790	0.54	2853	0.56	2973	0.62	3091	0.68	3212	0.75	3335	0.82	3455	0.89	3571	0.97		
455	5000	2797	0.55	2866	0.59	2930	0.62	3048	0.68	3161	0.74	3275	0.80	3393	0.88	3510	0.95	3625	1.03		
473	5200	2873	0.60	2943	0.64	3007	0.67	3124	0.74	3233	0.80	3342	0.86	3454	0.94	3568	1.01	3680	1.09		
491	5400	2949	0.66	3019	0.70	3084	0.73	3200	0.80	3308	0.86	3412	0.93	3518	1.00	3627	1.08	3736	1.15		
510	5600	3030	0.72	3099	0.76	3164	0.80	3282	0.87	3387	0.93	3489	1.00	3590	1.07	3693	1.15	3798	1.23		
528	5800	3108	0.78	3176	0.82	3241	0.86	3359	0.94	3464	1.01	3563	1.08	3660	1.15	3758	1.22	3859	1.30		
CFM	OV	6" SP		7" SP		8" SP		9" SP		10" SP		11" SP		12" SP		13" SP		14" SP			
		RPM	BHP	RPM	BHP	RPM	BHP	RPM	BHP	RPM	BHP	RPM	BHP	RPM	BHP	RPM	BHP	RPM	BHP	RPM	BHP
218	2400																				
237	2600	3271	0.56																		
255	2800	3310	0.60																		
273	3000	3351	0.65	3531	0.70																
291	3200	3394	0.69	3570	0.75	3776	0.86														
309	3400	3438	0.73	3610	0.80	3814	0.92	4008	1.03												
328	3600	3487	0.78	3653	0.85	3854	0.97	4046	1.09	4229	1.21	4405	1.33								
346	3800	3535	0.83	3699	0.91	3899	1.04	4089	1.16	4270	1.29	4444	1.42								
364	4000	3583	0.88	3745	0.96	3943	1.09	4131	1.23	4311	1.36										
382	4200	3632	0.94	3792	1.02	3989	1.15	4175	1.29	4353	1.44										
400	4400	3681	0.99	3840	1.07	4035	1.21	4220	1.36	4397	1.51										
419	4600	3735	1.05	3888	1.13	4083	1.28	4266	1.43	4442	1.58										
437	4800	3787	1.12	3940	1.20	4133	1.35	4316	1.50												
455	5000	3841	1.18	3990	1.27	4182	1.42	4364	1.58												
473	5200	3895	1.25	4042	1.34	4232	1.50	4413	1.66												
491	5400	3949	1.32	4094	1.41	4282	1.57	4462	1.74												
510	5600	4006	1.40	4147	1.49	4334	1.65														
528	5800	4062	1.47	4204	1.57	4389	1.74														
546	6000	4119	1.56	4258	1.65	4443	1.83														
564	6200	4178	1.64	4312	1.74																
582	6400	4240	1.73	4367	1.83																

Performance Data

RBF 12

Outlet Area = 0.131 Sq. Ft.

Wheel Dia. = 12.5

Tip Speed = 3.272 x RPM

CFM	OV	0.125" SP		0.25" SP		0.375" SP		0.5" SP		0.625" SP		0.75" SP		0.875" SP		1" SP		1.25" SP	
		RPM	BHP	RPM	BHP	RPM	BHP	RPM	BHP	RPM	BHP	RPM	BHP	RPM	BHP	RPM	BHP	RPM	BHP
131	1000	535	0.01	652	0.01	749	0.02	833	0.02	909	0.03	979	0.03	1044	0.04	1105	0.04	1220	0.05
157	1200	593	0.01	700	0.02	792	0.02	874	0.03	948	0.03	1016	0.04	1079	0.05	1139	0.05	1249	0.06
183	1400	653	0.02	752	0.02	839	0.03	917	0.03	989	0.04	1056	0.05	1117	0.05	1175	0.06	1283	0.07
210	1600	719	0.02	811	0.03	892	0.04	966	0.04	1035	0.05	1100	0.06	1160	0.07	1217	0.07	1322	0.09
236	1800	783	0.03	871	0.04	947	0.04	1017	0.05	1083	0.06	1145	0.07	1203	0.08	1259	0.08	1363	0.10
262	2000	849	0.04	932	0.04	1004	0.05	1071	0.06	1133	0.07	1193	0.08	1249	0.09	1303	0.10	1404	0.12
288	2200	916	0.05	994	0.06	1064	0.06	1127	0.07	1187	0.08	1244	0.09	1298	0.10	1350	0.11	1448	0.13
314	2400	984	0.06	1058	0.07	1125	0.08	1186	0.09	1242	0.10	1297	0.11	1349	0.12	1399	0.13	1494	0.15
341	2600	1055	0.07	1126	0.08	1189	0.09	1248	0.11	1303	0.12	1355	0.13	1405	0.14	1453	0.15	1545	0.17
367	2800	1125	0.09	1192	0.10	1253	0.11	1309	0.12	1362	0.14	1412	0.15	1460	0.16	1507	0.17	1596	0.20
393	3000	1195	0.11	1259	0.12	1317	0.13	1372	0.14	1423	0.16	1471	0.17	1518	0.18	1562	0.20	1649	0.22
419	3200	1265	0.13	1326	0.14	1382	0.15	1435	0.17	1484	0.18	1532	0.19	1577	0.21	1620	0.22	1703	0.25
445	3400	1336	0.15	1394	0.16	1449	0.18	1499	0.19	1547	0.21	1593	0.22	1637	0.24	1679	0.25	1759	0.28
472	3600	1409	0.18	1465	0.19	1518	0.21	1567	0.22	1613	0.24	1657	0.25	1700	0.27	1741	0.28	1819	0.32
498	3800	1481	0.20	1535	0.22	1585	0.24	1632	0.25	1677	0.27	1720	0.29	1762	0.30	1802	0.32	1878	0.35
524	4000	1552	0.24	1604	0.25	1653	0.27	1699	0.29	1742	0.31	1784	0.32	1824	0.34	1863	0.36	1938	0.39
550	4200	1624	0.27	1674	0.29	1721	0.31	1765	0.33	1808	0.35	1848	0.36	1888	0.38	1926	0.40	1999	0.43
576	4400	1696	0.31	1744	0.33	1789	0.35	1833	0.37	1874	0.39	1913	0.41	1952	0.42	1989	0.44	2060	0.48
603	4600	1771	0.35	1817	0.37	1861	0.40	1903	0.42	1943	0.44	1982	0.46	2019	0.47	2055	0.49	2124	0.53
629	4800	1844	0.40	1888	0.42	1930	0.44	1971	0.46	2010	0.48	2048	0.51	2084	0.53	2119	0.55	2187	0.59
655	5000	1916	0.45	1959	0.47	2000	0.49	2039	0.52	2077	0.54	2114	0.56	2150	0.58	2184	0.60	2250	0.64
681	5200	1989	0.50	2030	0.53	2070	0.55	2108	0.57	2145	0.60	2181	0.62	2216	0.64	2249	0.66	2314	0.71
CFM	OV	1.5" SP		1.75" SP		2" SP		2.5" SP		3" SP		3.5" SP		4" SP		4.5" SP		5" SP	
		RPM	BHP	RPM	BHP	RPM	BHP	RPM	BHP	RPM	BHP	RPM	BHP	RPM	BHP	RPM	BHP	RPM	BHP
210	1600	1419	0.10	1509	0.12	1594	0.14	1751	0.17	1897	0.20	2035	0.24						
236	1800	1457	0.12	1546	0.14	1629	0.15	1784	0.19	1926	0.23	2058	0.27	2184	0.31	2306	0.35		
262	2000	1498	0.14	1585	0.16	1667	0.18	1819	0.21	1959	0.26	2089	0.30	2211	0.34	2328	0.38	2441	0.43
288	2200	1540	0.16	1626	0.18	1707	0.20	1856	0.24	1994	0.28	2123	0.33	2243	0.37	2357	0.42	2466	0.47
314	2400	1584	0.17	1668	0.20	1748	0.22	1896	0.27	2031	0.32	2158	0.36	2277	0.41	2390	0.46	2497	0.51
341	2600	1632	0.19	1714	0.22	1792	0.25	1938	0.30	2072	0.35	2197	0.40	2314	0.45	2426	0.50	2533	0.55
367	2800	1680	0.22	1760	0.24	1837	0.27	1980	0.33	2113	0.38	2236	0.44	2352	0.49	2462	0.55	2567	0.60
393	3000	1730	0.25	1808	0.27	1883	0.30	2024	0.36	2155	0.42	2277	0.48	2392	0.54	2500	0.59	2604	0.65
419	3200	1782	0.28	1858	0.31	1931	0.33	2069	0.39	2197	0.45	2318	0.52	2432	0.58	2540	0.65	2643	0.71
445	3400	1836	0.31	1910	0.34	1981	0.37	2115	0.43	2242	0.49	2361	0.56	2474	0.63	2581	0.70	2683	0.76
472	3600	1893	0.35	1965	0.38	2034	0.41	2166	0.47	2289	0.53	2406	0.60	2518	0.68	2624	0.75	2725	0.82
498	3800	1950	0.39	2020	0.42	2087	0.45	2216	0.52	2337	0.58	2451	0.65	2561	0.73	2666	0.80	2767	0.88
524	4000	2008	0.43	2076	0.46	2141	0.50	2267	0.57	2385	0.63	2498	0.70	2606	0.78	2710	0.86	2809	0.94
550	4200	2068	0.47	2133	0.51	2197	0.55	2320	0.62	2436	0.69	2546	0.76	2652	0.83	2754	0.91	2852	1.00
576	4400	2128	0.52	2192	0.56	2254	0.60	2373	0.68	2487	0.75	2596	0.82	2700	0.90	2800	0.98	2896	1.06
603	4600	2191	0.57	2254	0.61	2314	0.65	2431	0.74	2542	0.82	2648	0.89	2751	0.97	2849	1.05	2944	1.13
629	4800	2252	0.63	2314	0.67	2373	0.71	2487	0.80	2596	0.89	2700	0.96	2801	1.04	2897	1.12	2991	1.21
655	5000	2314	0.69	2375	0.73	2433	0.77	2545	0.87	2651	0.96	2753	1.04	2852	1.12	2947	1.20	3039	1.29
681	5200	2376	0.75	2436	0.79	2494	0.84	2603	0.93	2707	1.03	2807	1.12	2904	1.21	2998	1.29	3088	1.38
707	5400	2439	0.82	2498	0.86	2555	0.91	2662	1.01	2764	1.11	2862	1.20	2957	1.29	3049	1.38	3139	1.47
734	5600	2506	0.89	2563	0.94	2618	0.99	2724	1.09	2824	1.19	2920	1.29	3014	1.39	3104	1.48	3192	1.58
760	5800	2570	0.97	2626	1.02	2680	1.07	2785	1.17	2883	1.27	2977	1.38	3069	1.48	3158	1.59	3244	1.68
CFM	OV	6" SP		7" SP		8" SP		9" SP		10" SP		11" SP		12" SP		13" SP		14" SP	
		RPM	BHP	RPM	BHP	RPM	BHP	RPM	BHP	RPM	BHP	RPM	BHP	RPM	BHP	RPM	BHP	RPM	BHP
314	2400	2700	0.61	2891	0.72	3074	0.83												
341	2600	2732	0.66	2918	0.77	3096	0.89	3266	1.01										
367	2800	2766	0.71	2949	0.83	3123	0.95	3289	1.07	3448	1.20	3603	1.33						
393	3000	2800	0.77	2983	0.89	3154	1.02	3316	1.14	3473	1.27	3624	1.41	3771	1.55	3913	1.69		
419	3200	2836	0.83	3017	0.96	3187	1.09	3348	1.22	3501	1.35	3649	1.49	3793	1.63	3932	1.78	4069	1.93
445	3400	2874	0.89	3053	1.02	3222	1.16	3381	1.30	3533	1.44	3679	1.58	3820	1.73	3956	1.87	4090	2.03
472	3600	2915	0.96	3091	1.10	3258	1.24	3417	1.38	3568	1.53	3712	1.68	3851	1.83	3985	1.98		
498	3800	2955	1.03	3130	1.18	3295	1.32	3452	1.47	3603	1.62	3746	1.78	3884	1.93	4017	2.09		
524	4000	2996	1.10	3170	1.26	3334	1.41	3489	1.56	3638	1.72	3781	1.88	3918	2.04	4050	2.20		
550	4200	3038	1.17	3211	1.34	3373	1.50	3527	1.66	3674	1.82	3816	1.98	3953	2.15	4084	2.32		
576	4400	3080	1.24	3252	1.42	3414	1.59	3567	1.76	3712	1.93	3853	2.10	3988	2.27				
603	4600	3125	1.31	3296	1.50	3456	1.69	3608	1.87	3753	2.04	3892	2.22	4026	2.40				
629	4800	3170	1.39	3338	1.58	3498	1.78	3649	1.97	3793	2.16	3931	2.34	4064	2.53				
655	5000	3215	1.47	3382	1.67	3540	1.87	3691	2.08	3834	2.28	3971	2.47						
681	5200	3262	1.56	3426	1.75	3583	1.97	3733	2.18	3875	2.39	4012	2.60						
707	5400	3309	1.65	3472	1.85	3627	2.06	3775	2.28	3917	2.51	4053	2.72						
734	5600	3360	1.76	3520	1.95	3673	2.17	3820	2.39	3961	2.63								
760	5800	3410	1.87	3568	2.06	3719	2.28	3864	2.51	4004	2.74								
786	6000	3461	1.99	3617	2.18	3766	2.39	3909	2.62	4047	2.86								
812	6200	3512	2.11	3666	2.31	3813	2.52	3955	2.75										
838	6400	3565	2.24	3716	2.44	386													

Performance Data

RBF 13

Outlet Area = 0.263 Sq. Ft.

Wheel Dia. = 13.5

Tip Speed = 3.534 x RPM

CFM	OV	0.125" SP		0.25" SP		0.375" SP		0.5" SP		0.625" SP		0.75" SP		0.875" SP		1" SP		1.25" SP			
		RPM	BHP	RPM	BHP	RPM	BHP	RPM	BHP	RPM	BHP	RPM	BHP	RPM	BHP	RPM	BHP	RPM	BHP	RPM	BHP
263	1000	563	0.02	656	0.03	736	0.04	809	0.04	878	0.05	943	0.06	1004	0.07	1062	0.08	1170	0.10		
316	1200	636	0.03	722	0.04	796	0.05	863	0.06	926	0.07	986	0.08	1043	0.09	1098	0.10	1201	0.12		
368	1400	709	0.04	791	0.05	860	0.06	923	0.08	981	0.09	1037	0.10	1090	0.11	1141	0.12	1239	0.15		
421	1600	786	0.06	863	0.07	929	0.08	988	0.10	1043	0.11	1095	0.12	1145	0.14	1193	0.15	1285	0.18		
473	1800	863	0.08	936	0.09	999	0.11	1055	0.12	1108	0.14	1157	0.15	1204	0.17	1249	0.18	1336	0.21		
526	2000	941	0.10	1011	0.12	1072	0.14	1126	0.15	1176	0.17	1223	0.19	1268	0.20	1311	0.22	1394	0.25		
579	2200	1021	0.13	1088	0.15	1146	0.17	1198	0.19	1246	0.21	1292	0.23	1335	0.24	1377	0.26	1455	0.30		
631	2400	1099	0.16	1164	0.19	1220	0.21	1270	0.23	1317	0.25	1361	0.27	1402	0.29	1443	0.31	1519	0.35		
684	2600	1180	0.21	1242	0.23	1296	0.26	1345	0.28	1390	0.30	1433	0.32	1473	0.34	1512	0.37	1586	0.41		
736	2800	1259	0.25	1320	0.28	1372	0.31	1419	0.33	1463	0.35	1505	0.38	1544	0.40	1581	0.43	1652	0.47		
789	3000	1341	0.30	1399	0.34	1450	0.37	1495	0.39	1538	0.42	1578	0.44	1617	0.47	1654	0.49	1722	0.54		
842	3200	1423	0.36	1478	0.40	1528	0.43	1573	0.46	1614	0.49	1653	0.52	1690	0.54	1726	0.57	1794	0.62		
894	3400	1503	0.43	1557	0.47	1605	0.50	1649	0.54	1689	0.57	1727	0.59	1764	0.62	1799	0.65	1865	0.71		
947	3600	1586	0.51	1637	0.55	1684	0.59	1727	0.62	1766	0.65	1803	0.68	1839	0.72	1873	0.75	1938	0.81		
999	3800	1667	0.59	1717	0.63	1762	0.67	1804	0.71	1843	0.75	1879	0.78	1914	0.82	1947	0.85	2010	0.91		
1052	4000	1750	0.68	1798	0.73	1842	0.77	1883	0.82	1921	0.85	1956	0.89	1990	0.92	2023	0.96	2085	1.03		
1105	4200	1833	0.79	1880	0.84	1922	0.88	1962	0.93	1999	0.97	2034	1.01	2067	1.04	2099	1.08	2164	1.15		
1157	4400	1915	0.90	1960	0.95	2001	1.00	2040	1.05	2076	1.09	2111	1.13	2143	1.17	2175	1.21	2234	1.29		
1210	4600	1999	1.02	2042	1.08	2082	1.13	2120	1.18	2155	1.23	2189	1.27	2221	1.31	2252	1.36	2310	1.44		
1262	4800	2081	1.16	2123	1.21	2162	1.27	2198	1.32	2233	1.37	2266	1.42	2298	1.46	2328	1.51	2385	1.59		
1315	5000	2165	1.30	2205	1.36	2243	1.42	2279	1.48	2313	1.53	2345	1.58	2377	1.63	2406	1.67	2463	1.77		
1368	5200	2248	1.46	2288	1.53	2325	1.59	2360	1.64	2393	1.70	2425	1.75	2455	1.80	2485	1.86	2540	1.95		
CFM	OV	1.5" SP		1.75" SP		2" SP		2.5" SP		3" SP		3.5" SP		4" SP		4.5" SP		5" SP			
		RPM	BHP	RPM	BHP	RPM	BHP	RPM	BHP	RPM	BHP	RPM	BHP	RPM	BHP	RPM	BHP	RPM	BHP	RPM	BHP
421	1600	1371	0.20	1454	0.23	1534	0.26	1682	0.33	1820	0.39	1949	0.46	2070	0.53	2185	0.61				
473	1800	1419	0.24	1497	0.27	1573	0.30	1716	0.37	1850	0.44	1976	0.51	2095	0.59	2208	0.67	2316	0.75		
526	2000	1472	0.28	1547	0.32	1619	0.35	1756	0.42	1886	0.49	2008	0.57	2124	0.65	2235	0.73	2341	0.82		
579	2200	1530	0.33	1602	0.37	1671	0.40	1802	0.48	1926	0.55	2045	0.63	2158	0.72	2266	0.81	2370	0.90		
631	2400	1590	0.39	1659	0.43	1725	0.47	1851	0.54	1971	0.62	2085	0.70	2195	0.79	2300	0.88	2402	0.98		
684	2600	1655	0.45	1721	0.49	1784	0.53	1906	0.62	2021	0.70	2131	0.79	2237	0.88	2339	0.97	2438	1.07		
736	2800	1720	0.52	1784	0.56	1845	0.61	1962	0.70	2074	0.79	2180	0.88	2282	0.97	2381	1.06	2477	1.16		
789	3000	1788	0.60	1850	0.64	1910	0.69	2023	0.79	2130	0.89	2234	0.98	2333	1.08	2428	1.17	2521	1.27		
842	3200	1857	0.68	1918	0.73	1976	0.78	2086	0.89	2190	0.99	2290	1.09	2386	1.20	2479	1.30	2569	1.40		
894	3400	1927	0.77	1986	0.83	2042	0.88	2150	0.99	2251	1.10	2348	1.21	2441	1.32	2532	1.43	2620	1.54		
947	3600	1999	0.87	2056	0.93	2111	0.99	2217	1.11	2315	1.23	2409	1.34	2500	1.46	2588	1.57	2674	1.69		
999	3800	2070	0.98	2126	1.04	2180	1.10	2283	1.23	2380	1.36	2472	1.48	2560	1.60	2645	1.72	2729	1.85		
1052	4000	2143	1.09	2199	1.16	2251	1.23	2351	1.37	2447	1.50	2537	1.63	2623	1.76	2706	1.89	2787	2.01		
1105	4200	2217	1.22	2272	1.30	2324	1.37	2422	1.51	2514	1.65	2603	1.79	2688	1.93	2769	2.06	2848	2.20		
1157	4400	2290	1.36	2344	1.44	2395	1.51	2491	1.66	2582	1.81	2669	1.96	2752	2.10	2832	2.24	2909	2.38		
1210	4600	2365	1.51	2418	1.59	2468	1.67	2563	1.83	2652	1.98	2737	2.14	2819	2.29	2898	2.44	2974	2.59		
1262	4800	2439	1.68	2491	1.76	2540	1.84	2634	2.00	2722	2.17	2805	2.33	2885	2.49	2963	2.65	3038	2.80		
1315	5000	2515	1.85	2566	1.94	2615	2.02	2707	2.19	2794	2.36	2875	2.53	2954	2.70	3030	2.87	3104	3.03		
1368	5200	2592	2.04	2642	2.13	2689	2.22	2781	2.40	2866	2.57	2946	2.75	3024	2.93	3098	3.10	3171	3.27		
1420	5400	2668	2.24	2717	2.33	2763	2.42	2853	2.61	2937	2.79	3017	2.98	3093	3.16	3166	3.34	3237	3.52		
1473	5600	2745	2.45	2793	2.55	2839	2.65	2927	2.84	3011	3.03	3089	3.22	3164	3.41	3236	3.60	3306	3.79		
1525	5800	2821	2.68	2869	2.78	2914	2.88	3001	3.08	3083	3.28	3161	3.47	3235	3.67	3306	3.87	3374	4.06		
CFM	OV	6" SP		7" SP		8" SP		9" SP		10" SP		11" SP		12" SP		13" SP		14" SP			
		RPM	BHP	RPM	BHP	RPM	BHP	RPM	BHP	RPM	BHP	RPM	BHP	RPM	BHP	RPM	BHP	RPM	BHP	RPM	BHP
631	2400	2594	1.17	2774	1.37	2944	1.58	3105	1.80	3259	2.02										
684	2600	2626	1.27	2803	1.48	2970	1.70	3130	1.93	3282	2.16										
736	2800	2661	1.37	2835	1.60	2999	1.82	3156	2.06	3306	2.29	3427	2.39	3567	2.63						
789	3000	2700	1.49	2870	1.72	3032	1.95	3186	2.20	3334	2.45	3476	2.70	3614	2.96	3723	3.05	3852	3.31		
842	3200	2743	1.62	2909	1.85	3067	2.09	3219	2.35	3365	2.61	3505	2.87	3640	3.14	3771	3.41	3898	3.69		
894	3400	2788	1.76	2950	1.99	3105	2.24	3254	2.50	3398	2.77	3536	3.04	3669	3.32	3798	3.60	3924	3.89		
947	3600	2838	1.92	2995	2.16	3146	2.41	3292	2.67	3433	2.95	3570	3.23	3701	3.52	3829	3.81	3952	4.11		
999	3800	2890	2.09	3043	2.33	3190	2.58	3333	2.85	3471	3.13	3605	3.42	3735	3.72	3861	4.02	3983	4.33		
1052	4000	2944	2.27	3094	2.53	3238	2.78	3377	3.05	3512	3.34	3644	3.63	3771	3.93	3896	4.25	4016	4.56		
1105	4200	3001	2.47	3148	2.74	3288	3.00	3424	3.27	3556	3.56	3685	3.86	3810	4.16	3933	4.48	4052	4.81		
1157	4400	3058	2.67	3202	2.95	3340	3.23	3473	3.51	3602	3.80	3728	4.10	3851	4.41	3971	4.73	4089	5.06		
1210	4600	3119	2.88	3259	3.18	3395	3.48	3525	3.77	3652	4.06	3775	4.36	3895	4.68	4013	5.00				
1262	4800	3181	3.11	3317	3.42	3450	3.73	3578	4.03	3703	4.34	3823	4.64	3941	4.96	4057	5.29				
1315	5000	3245	3.35	3379	3.67	3508	4.00	3634	4.32	3756	4.63	3875	4.95	3990	5.27						
1368	5200	3310	3.61	3441	3.94	3568	4.28	3691	4.61	3812	4.95	3928	5.28	4042	5.61						
1420	5400	3375	3.88	3504	4.22	3629															

Performance Data

RBF 15

Outlet Area = 0.478 Sq. Ft.

Wheel Dia. = 15.625

Tip Speed = 4.091 x RPM

CFM	OV	0.5" SP		1" SP		1.5" SP		2" SP		2.5" SP		3" SP		3.5" SP		4" SP		4.5" SP	
		RPM	BHP	RPM	BHP	RPM	BHP	RPM	BHP	RPM	BHP	RPM	BHP	RPM	BHP	RPM	BHP	RPM	BHP
478	1000	712	0.08	919	0.15	1085	0.21	1229	0.28	1360	0.35	1481	0.43	1593	0.51	1699	0.60	1799	0.69
574	1200	760	0.11	961	0.19	1121	0.27	1261	0.35	1386	0.42	1502	0.50	1611	0.59	1714	0.68	1812	0.77
669	1400	811	0.14	1004	0.23	1162	0.32	1297	0.41	1420	0.51	1532	0.60	1637	0.69	1736	0.78	1830	0.88
765	1600	866	0.19	1051	0.28	1205	0.38	1338	0.49	1457	0.59	1567	0.70	1670	0.81	1767	0.91	1858	1.01
860	1800	923	0.24	1100	0.34	1249	0.45	1380	0.57	1498	0.68	1606	0.81	1706	0.93	1801	1.05	1891	1.16
956	2000	984	0.30	1153	0.42	1297	0.53	1425	0.66	1541	0.79	1647	0.92	1746	1.05	1839	1.19	1927	1.32
1052	2200	1047	0.38	1207	0.50	1347	0.63	1471	0.76	1585	0.89	1690	1.04	1788	1.18	1879	1.33	1966	1.48
1147	2400	1112	0.47	1264	0.60	1398	0.74	1519	0.87	1630	1.01	1734	1.17	1830	1.33	1921	1.48	2007	1.64
1243	2600	1178	0.57	1323	0.71	1453	0.86	1570	1.01	1678	1.16	1779	1.31	1874	1.48	1964	1.65	2049	1.82
1338	2800	1246	0.70	1383	0.84	1508	1.00	1622	1.16	1728	1.32	1827	1.48	1920	1.65	2008	1.82	2092	2.01
1434	3000	1315	0.83	1445	0.98	1565	1.15	1677	1.33	1780	1.50	1876	1.66	1967	1.83	2054	2.02	2137	2.21
1530	3200	1385	0.99	1509	1.15	1625	1.32	1732	1.51	1833	1.69	1927	1.87	2017	2.05	2102	2.24	2183	2.43
1625	3400	1456	1.16	1574	1.33	1685	1.51	1789	1.71	1887	1.91	1979	2.10	2067	2.29	2150	2.48	2230	2.67
1721	3600	1527	1.36	1640	1.54	1747	1.73	1847	1.92	1943	2.14	2033	2.34	2119	2.55	2201	2.75	2279	2.95
1816	3800	1599	1.57	1707	1.77	1810	1.96	1907	2.16	2000	2.38	2088	2.61	2172	2.82	2252	3.03	2329	3.24
1912	4000	1672	1.81	1776	2.02	1874	2.22	1968	2.43	2058	2.65	2144	2.89	2227	3.12	2305	3.35	2381	3.57
2008	4200	1746	2.08	1845	2.29	1940	2.51	2031	2.72	2118	2.95	2202	3.19	2282	3.44	2360	3.68	2434	3.92
2103	4400	1819	2.36	1914	2.59	2006	2.82	2094	3.04	2178	3.27	2260	3.52	2338	3.77	2414	4.03	2487	4.28
2199	4600	1893	2.68	1985	2.92	2073	3.15	2158	3.38	2240	3.62	2319	3.87	2396	4.14	2471	4.41	2543	4.68
2294	4800	1967	3.02	2055	3.27	2141	3.52	2223	3.76	2303	4.01	2380	4.26	2455	4.53	2527	4.81	2598	5.09
CFM	OV	5" SP		5.5" SP		6" SP		6.5" SP		7" SP		7.5" SP		8" SP		8.5" SP		9" SP	
		RPM	BHP	RPM	BHP	RPM	BHP	RPM	BHP	RPM	BHP	RPM	BHP	RPM	BHP	RPM	BHP	RPM	BHP
765	1600	1946	1.12	2030	1.22	2112	1.34	2191	1.46	2268	1.58	2343	1.71	2415	1.83	2486	1.97	2555	2.10
860	1800	1977	1.28	2059	1.40	2138	1.51	2215	1.63	2289	1.75	2362	1.88	2433	2.01	2503	2.15	2571	2.29
956	2000	2012	1.45	2093	1.59	2171	1.71	2245	1.84	2318	1.97	2389	2.10	2458	2.23	2525	2.37	2591	2.50
1052	2200	2049	1.63	2129	1.78	2206	1.92	2280	2.07	2351	2.21	2421	2.35	2488	2.49	2554	2.63	2618	2.77
1147	2400	2089	1.80	2167	1.96	2242	2.12	2315	2.29	2386	2.45	2455	2.61	2522	2.76	2587	2.92	2650	3.07
1243	2600	2130	1.99	2208	2.16	2282	2.34	2354	2.51	2424	2.69	2491	2.86	2557	3.04	2622	3.21	2685	3.39
1338	2800	2173	2.19	2250	2.38	2323	2.56	2394	2.75	2463	2.93	2530	3.12	2595	3.31	2658	3.50	2720	3.69
1434	3000	2216	2.40	2292	2.60	2366	2.80	2436	3.00	2505	3.20	2571	3.40	2635	3.60	2697	3.80	2758	4.00
1530	3200	2261	2.63	2337	2.84	2409	3.05	2479	3.26	2547	3.47	2613	3.68	2676	3.89	2738	4.11	2798	4.32
1625	3400	2307	2.88	2381	3.09	2453	3.31	2522	3.53	2590	3.76	2655	3.98	2718	4.21	2780	4.43	2839	4.65
1721	3600	2355	3.16	2428	3.37	2499	3.60	2567	3.83	2634	4.06	2698	4.30	2761	4.54	2822	4.77	2882	5.01
1816	3800	2404	3.46	2475	3.68	2545	3.90	2613	4.14	2678	4.38	2742	4.63	2804	4.87	2865	5.13	2924	5.37
1912	4000	2454	3.79	2525	4.02	2593	4.25	2660	4.49	2725	4.73	2788	4.98	2849	5.24	2909	5.50	2968	5.76
2008	4200	2506	4.15	2575	4.38	2643	4.62	2708	4.86	2772	5.11	2834	5.36	2895	5.62	2955	5.89	3013	6.16
2103	4400	2558	4.53	2626	4.78	2693	5.02	2757	5.27	2820	5.52	2882	5.78	2942	6.04	3000	6.31	3058	6.59
2199	4600	2612	4.94	2679	5.20	2745	5.46	2808	5.71	2870	5.97	2931	6.23	2990	6.50	3048	6.77	3105	7.05
2294	4800	2666	5.37	2732	5.64	2797	5.91	2859	6.18	2921	6.45	2980	6.71	3039	6.99	3096	7.26	3152	7.54
2390	5000	2722	5.82	2787	6.11	2851	6.40	2912	6.68	2973	6.96	3031	7.23	3089	7.51	3146	7.80	3201	8.08
2486	5200	2779	6.31	2843	6.61	2905	6.91	2966	7.21	3025	7.49	3084	7.79	3140	8.07	3196	8.36	3251	8.66
2581	5400	2835	6.81	2899	7.13	2960	7.44	3020	7.75	3079	8.06	3136	8.36	3192	8.66	3247	8.96	3301	9.26
2677	5600	2894	7.35	2956	7.68	3016	8.00	3076	8.34	3133	8.65	3190	8.98	3245	9.29	3299	9.60	3353	9.91
2772	5800	2953	7.92	3013	8.25	3073	8.59	3131	8.93	3188	9.27	3244	9.61	3298	9.93				
CFM	OV	10" SP		11" SP		12" SP		13" SP		14" SP		15" SP		16" SP		17" SP		18" SP	
		RPM	BHP	RPM	BHP	RPM	BHP	RPM	BHP	RPM	BHP	RPM	BHP	RPM	BHP	RPM	BHP	RPM	BHP
1243	2600	2805	3.72	2921	4.05	3032	4.38	3140	4.72	3245	5.07	3347	5.43	3447	5.80	3545	6.18	3641	6.58
1338	2800	2840	4.06	2955	4.43	3065	4.79	3171	5.14	3274	5.50	3374	5.87	3472	6.24	3567	6.62	3661	7.02
1434	3000	2876	4.40	2990	4.81	3099	5.20	3205	5.59	3306	5.97	3405	6.36	3501	6.74	3595	7.13		
1530	3200	2915	4.75	3027	5.19	3135	5.62	3240	6.05	3341	6.46	3439	6.88	3533	7.28	3626	7.69		
1625	3400	2955	5.11	3066	5.57	3172	6.02	3275	6.48	3376	6.94	3473	7.39	3568	7.84	3659	8.27		
1721	3600	2997	5.49	3106	5.96	3212	6.45	3314	6.93	3413	7.42	3509	7.90	3603	8.39				
1816	3800	3039	5.88	3148	6.38	3252	6.88	3353	7.39	3451	7.90	3546	8.41	3639	8.93				
1912	4000	3081	6.28	3190	6.81	3294	7.34	3395	7.87	3492	8.41	3586	8.94						
2008	4200	3125	6.71	3233	7.27	3337	7.82	3437	8.37	3533	8.92	3627	9.49						
2103	4400	3169	7.15	3276	7.73	3379	8.31	3479	8.89	3575	9.46	3668	10.05						
2199	4600	3215	7.63	3321	8.22	3423	8.82	3522	9.43	3618	10.04								
2294	4800	3261	8.12	3366	8.73	3467	9.35	3565	9.97	3660	10.61								
2390	5000	3308	8.66	3412	9.27	3512	9.90	3610	10.56										
2486	5200	3357	9.25	3459	9.86	3559	10.50	3655	11.16										
2581	5400	3406	9.87	3507	10.49	3605	11.13												
2677	5600	3456	10.53	3557	11.17	3654	11.82												
2772	5800	3507	11.23	3606	11.87														
2868	6000	3559	11.97	3657	12.63														
2964	6200	3612	12.74																
3059	6400	3665	13.54																

Performance shown is with inlet and outlet ducts.
 BHP shown does not include drive losses.
 Underlined figures indicate maximum static efficiency.

Performance Data

RBF 19

Outlet Area = 0.673 Sq. Ft.

Wheel Dia. = 19.125

Tip Speed = 5.007 x RPM

CFM	OV	0.5" SP		1" SP		1.5" SP		2" SP		2.5" SP		3" SP		3.5" SP		4" SP		4.5" SP	
		RPM	BHP	RPM	BHP	RPM	BHP	RPM	BHP	RPM	BHP	RPM	BHP	RPM	BHP	RPM	BHP	RPM	BHP
673	1000	571	0.11	742	0.21	879	0.30	998	0.39	1106	0.50	1206	0.61	1298	0.73	1385	0.86	1467	1.00
808	1200	606	0.15	772	0.26	905	0.37	1020	0.48	1124	0.59	1220	0.71	1310	0.83	1395	0.97	1476	1.11
942	1400	645	0.19	805	0.31	935	0.44	1047	0.58	1148	0.71	1241	0.83	1327	0.96	1410	1.10	1488	1.24
1077	1600	686	0.25	840	0.38	967	0.53	1077	0.68	1176	0.83	1267	0.98	1351	1.12	1431	1.27	1506	1.41
1211	1800	729	0.32	877	0.46	1000	0.62	1109	0.78	1206	0.95	1294	1.12	1378	1.29	1456	1.46	1530	1.62
1346	2000	774	0.40	916	0.56	1036	0.72	1142	0.90	1238	1.09	1325	1.27	1407	1.46	1483	1.65	1557	1.84
1481	2200	821	0.49	957	0.67	1073	0.84	1177	1.03	1271	1.23	1358	1.44	1438	1.64	1513	1.85	1585	2.06
1615	2400	870	0.60	999	0.79	1112	0.99	1212	1.18	1305	1.39	1390	1.61	1470	1.83	1545	2.05	1615	2.28
1750	2600	920	0.74	1043	0.94	1152	1.15	1250	1.35	1340	1.56	1424	1.79	1503	2.04	1577	2.28	1647	2.52
1884	2800	971	0.89	1088	1.10	1194	1.33	1289	1.54	1377	1.77	1460	2.00	1537	2.25	1610	2.51	1680	2.77
2019	3000	1023	1.06	1135	1.28	1237	1.52	1330	1.76	1416	2.00	1496	2.24	1572	2.49	1644	2.76	1713	3.04
2154	3200	1076	1.25	1183	1.49	1281	1.74	1372	2.00	1456	2.25	1534	2.50	1609	2.76	1680	3.04	1747	3.32
2288	3400	1130	1.47	1232	1.72	1326	1.98	1414	2.25	1496	2.53	1573	2.79	1646	3.06	1716	3.34	1782	3.63
2423	3600	1185	1.72	1282	1.98	1372	2.24	1458	2.53	1538	2.83	1614	3.12	1685	3.39	1753	3.68	1819	3.98
2557	3800	1239	1.99	1332	2.26	1420	2.54	1502	2.83	1581	3.15	1655	3.46	1725	3.76	1792	4.05	1856	4.35
2692	4000	1295	2.29	1384	2.58	1468	2.86	1548	3.17	1624	3.49	1697	3.82	1766	4.15	1831	4.45	1895	4.77
2827	4200	1351	2.62	1436	2.92	1517	3.22	1595	3.53	1669	3.87	1740	4.22	1807	4.55	1872	4.89	1934	5.22
2961	4400	1407	2.98	1489	3.30	1567	3.61	1642	3.93	1714	4.27	1783	4.63	1850	5.00	1913	5.35	1974	5.69
3096	4600	1463	3.37	1542	3.71	1618	4.04	1691	4.37	1760	4.71	1828	5.08	1893	5.46	1955	5.84	2015	6.20
3230	4800	1520	3.80	1596	4.15	1669	4.49	1740	4.84	1807	5.18	1873	5.56	1936	5.95	1998	6.35	2057	6.74
CFM	OV	5" SP		5.5" SP		6" SP		6.5" SP		7" SP		7.5" SP		8" SP		8.5" SP		9" SP	
		RPM	BHP	RPM	BHP	RPM	BHP	RPM	BHP	RPM	BHP	RPM	BHP	RPM	BHP	RPM	BHP	RPM	BHP
1077	1600	1579	1.57	1649	1.73	1717	1.90	1783	2.08	1846	2.26	1908	2.44	1967	2.63	2025	2.83	2082	3.03
1211	1800	1601	1.78	1669	1.95	1734	2.11	1798	2.29	1860	2.47	1921	2.67	1980	2.86	2037	3.07	2093	3.27
1346	2000	1626	2.02	1693	2.20	1757	2.38	1819	2.56	1879	2.75	1938	2.94	1995	3.13	2051	3.34	2106	3.55
1481	2200	1654	2.27	1720	2.47	1783	2.67	1844	2.87	1903	3.07	1960	3.27	2016	3.47	2070	3.67	2124	3.88
1615	2400	1683	2.51	1747	2.73	1810	2.96	1870	3.19	1929	3.41	1985	3.62	2040	3.84	2094	4.06	2146	4.27
1750	2600	1714	2.76	1777	3.00	1839	3.25	1898	3.50	1956	3.75	2012	3.99	2067	4.23	2120	4.47	2171	4.70
1884	2800	1746	3.03	1809	3.29	1870	3.56	1928	3.82	1985	4.08	2040	4.35	2094	4.62	2146	4.88	2198	5.14
2019	3000	1779	3.32	1841	3.59	1902	3.87	1960	4.15	2016	4.44	2070	4.72	2123	5.00	2175	5.29	2225	5.57
2154	3200	1812	3.62	1874	3.91	1934	4.21	1992	4.51	2048	4.81	2101	5.10	2154	5.41	2205	5.71	2255	6.01
2288	3400	1846	3.93	1908	4.25	1967	4.56	2024	4.87	2080	5.19	2133	5.50	2185	5.82	2236	6.14	2285	6.46
2423	3600	1882	4.28	1942	4.60	2001	4.93	2058	5.26	2113	5.60	2166	5.93	2218	6.26	2268	6.60	2317	6.93
2557	3800	1918	4.66	1978	4.99	2036	5.33	2092	5.67	2146	6.02	2199	6.37	2250	6.72	2301	7.08	2349	7.42
2692	4000	1956	5.09	2014	5.41	2072	5.76	2127	6.11	2181	6.47	2233	6.83	2284	7.20	2334	7.57	2382	7.94
2827	4200	1994	5.55	2052	5.88	2108	6.22	2163	6.58	2216	6.95	2268	7.32	2318	7.70	2367	8.08	2415	8.47
2961	4400	2033	6.04	2090	6.38	2146	6.74	2200	7.10	2252	7.46	2303	7.84	2353	8.23	2402	8.63	2449	9.03
3096	4600	2073	6.57	2130	6.93	2184	7.29	2237	7.65	2289	8.03	2339	8.41	2389	8.81	2437	9.21	2484	9.62
3230	4800	2114	7.13	2169	7.50	2223	7.88	2276	8.26	2327	8.64	2376	9.02	2425	9.42	2473	9.83	2519	10.24
3365	5000	2156	7.72	2210	8.11	2263	8.50	2315	8.90	2365	9.29	2414	9.68	2462	10.08	2509	10.49	2555	10.91
3500	5200	2198	8.34	2252	8.76	2304	9.17	2355	9.58	2405	9.99	2453	10.39	2501	10.81	2547	11.22	2593	11.65
3634	5400	2241	8.99	2294	9.43	2345	9.86	2396	10.30	2444	10.71	2492	11.13	2539	11.56	2585	11.99	2630	12.42
3769	5600	2285	9.68	2337	10.14	2388	10.60	2437	11.05	2485	11.49	2533	11.94	2579	12.37	2624	12.80	2669	13.25
3903	5800	2329	10.41	2380	10.88	2430	11.36	2479	11.83	2526	12.29	2573	12.76	2619	13.22	2663	13.66	2707	14.11
CFM	OV	10" SP		11" SP		12" SP		13" SP		14" SP		15" SP		16" SP		17" SP		18" SP	
		RPM	BHP	RPM	BHP	RPM	BHP	RPM	BHP	RPM	BHP	RPM	BHP	RPM	BHP	RPM	BHP	RPM	BHP
1750	2600	2271	5.17	2366	5.64	2459	6.13	2548	6.62	2635	7.14	2721	7.68	2804	8.24	2884	8.81	2963	9.40
1884	2800	2296	5.65	2390	6.15	2481	6.66	2569	7.17	2655	7.69	2738	8.23	2819	8.78	2899	9.36	2977	9.96
2019	3000	2323	6.14	2417	6.69	2507	7.24	2593	7.77	2677	8.31	2759	8.86	2839	9.42	2917	10.00	2993	10.58
2154	3200	2351	6.62	2444	7.23	2533	7.82	2619	8.40	2702	8.98	2783	9.56	2861	10.13	2938	10.72		
2288	3400	2380	7.10	2472	7.75	2560	8.39	2646	9.04	2729	9.67	2808	10.27	2886	10.89	2962	11.50		
2423	3600	2411	7.61	2502	8.29	2589	8.97	2674	9.66	2756	10.34	2835	11.01	2912	11.67	2987	12.32		
2557	3800	2443	8.13	2533	8.85	2619	9.56	2703	10.29	2784	11.01	2862	11.72	2939	12.44				
2692	4000	2476	8.69	2565	9.43	2650	10.17	2733	10.93	2813	11.69	2891	12.45	2967	13.21				
2827	4200	2508	9.25	2597	10.03	2683	10.82	2765	11.61	2844	12.39	2921	13.19						
2961	4400	2541	9.84	2630	10.66	2715	11.48	2796	12.28	2875	13.11	2952	13.94						
3096	4600	2575	10.45	2663	11.31	2748	12.17	2829	13.01	2908	13.87	2984	14.73						
3230	4800	2610	11.10	2697	11.98	2781	12.87	2862	13.76	2940	14.65								
3365	5000	2645	11.79	2731	12.68	2814	13.59	2895	14.53	2973	15.46								
3500	5200	2681	12.52	2766	13.42	2849	14.37	2929	15.33										
3634	5400	2717	13.29	2802	14.22	2884	15.17	2963	16.15										
3769	5600	2755	14.14	2838	15.06	2919	16.02												
3903	5800	2793	15.03	2875	15.96	2956	16.94												
4038	6000	2832	15.98	2913	16.92	2993	17.91												
4173	6200	2871	16.97	2952	17.95														
4307	6400	2911	18.01	2991	19.01														

Performance shown is with inlet and outlet ducts.
 BHP shown does not include drive losses.
Underlined figures indicate maximum static efficiency.

Performance Data

RBF 22

Outlet Area = .938 Sq. Ft.

Wheel Dia. = 22.625

Tip Speed = 5.923 x RPM

CFM	OV	0.5" SP		1" SP		1.5" SP		2" SP		2.5" SP		3" SP		3.5" SP		4" SP		4.5" SP	
		RPM	BHP	RPM	BHP	RPM	BHP	RPM	BHP	RPM	BHP	RPM	BHP	RPM	BHP	RPM	BHP	RPM	BHP
938	1000	474	0.14	618	0.25	733	0.37	835	0.50	928	0.64								
1126	1200	503	0.18	642	0.31	754	0.45	851	0.59	939	0.74								
1313	1400	536	0.24	668	0.39	777	0.54	873	0.71	958	0.87	1036	1.04	1109	1.21	1180	1.40	1247	1.60
1501	1600	572	0.31	697	0.47	803	0.65	896	0.83	979	1.01	1056	1.20	1127	1.39	1195	1.58	1259	1.78
1688	1800	611	0.40	728	0.57	830	0.76	921	0.96	1003	1.16	1078	1.37	1149	1.58	1215	1.80	1277	2.01
1876	2000	652	0.51	761	0.69	860	0.89	948	1.11	1028	1.33	1102	1.56	1171	1.79	1236	2.02	1298	2.25
2064	2200	694	0.64	797	0.83	891	1.04	976	1.27	1055	1.51	1128	1.76	1195	2.01	1259	2.26	1320	2.51
2251	2400	736	0.78	835	0.99	924	1.21	1007	1.45	1083	1.71	1154	1.98	1221	2.25	1284	2.52	1344	2.79
2439	2600	779	0.95	875	1.19	959	1.42	1038	1.66	1113	1.93	1182	2.21	1248	2.50	1310	2.80	1369	3.09
2626	2800	823	1.14	916	1.40	996	1.65	1072	1.91	1144	2.18	1211	2.46	1276	2.78	1337	3.09	1395	3.40
2814	3000	867	1.36	958	1.65	1034	1.91	1107	2.18	1176	2.46	1242	2.76	1305	3.07	1365	3.40	1422	3.74
3002	3200	912	1.61	1000	1.92	1075	2.20	1143	2.48	1210	2.78	1274	3.08	1336	3.41	1394	3.74	1450	4.09
3189	3400	957	1.89	1043	2.22	1116	2.53	1182	2.82	1246	3.13	1308	3.45	1367	3.77	1424	4.11	1479	4.47
3377	3600	1002	2.19	1086	2.56	1158	2.89	1222	3.20	1283	3.52	1342	3.84	1400	4.18	1456	4.53	1510	4.90
3564	3800	1048	2.53	1129	2.92	1200	3.28	1263	3.62	1321	3.94	1378	4.28	1434	4.63	1489	5.00	1541	5.36
3752	4000	1094	2.90	1173	3.32	1242	3.71	1304	4.07	1361	4.41	1416	4.76	1470	5.12	1523	5.50	1574	5.88
3940	4200	1141	3.32	1217	3.76	1285	4.17	1346	4.56	1402	4.92	1455	5.29	1506	5.65	1558	6.04	1608	6.44
4127	4400	1187	3.76	1261	4.23	1328	4.67	1388	5.08	1443	5.47	1494	5.84	1544	6.23	1594	6.63	1642	7.03
4315	4600	1235	4.27	1306	4.75	1371	5.21	1431	5.66	1485	6.07	1535	6.46	1584	6.86	1631	7.26	1678	7.68
4502	4800	1282	4.80	1351	5.30	1414	5.79	1473	6.26	1527	6.71	1577	7.13	1624	7.54	1670	7.95	1715	8.37
CFM	OV	5" SP		5.5" SP		6" SP		6.5" SP		7" SP		7.5" SP		8" SP		8.5" SP		9" SP	
		RPM	BHP	RPM	BHP	RPM	BHP	RPM	BHP	RPM	BHP	RPM	BHP	RPM	BHP	RPM	BHP	RPM	BHP
1501	1600	1321	2.00	1381	2.22	1439	2.44	1495	2.67										
1688	1800	1337	2.23	1394	2.45	1450	2.68	1505	2.93	1558	3.18	1609	3.43	1660	3.69				
1876	2000	1357	2.49	1413	2.73	1467	2.97	1519	3.21	1570	3.47	1620	3.73	1669	4.00	1717	4.27	1764	4.55
2064	2200	1378	2.77	1434	3.03	1487	3.29	1538	3.55	1588	3.81	1637	4.08	1684	4.35	1730	4.63	1776	4.92
2251	2400	1401	3.07	1456	3.35	1509	3.63	1560	3.91	1609	4.19	1656	4.47	1703	4.76	1748	5.05	1792	5.34
2439	2600	1425	3.38	1479	3.68	1531	3.98	1582	4.28	1630	4.58	1678	4.89	1724	5.20	1768	5.50	1811	5.81
2626	2800	1450	3.71	1504	4.03	1555	4.35	1605	4.67	1653	5.00	1700	5.32	1745	5.65	1790	5.98	1833	6.31
2814	3000	1477	4.08	1529	4.41	1580	4.75	1629	5.09	1677	5.43	1723	5.77	1768	6.12	1812	6.47	1854	6.81
3002	3200	1504	4.45	1556	4.81	1606	5.17	1655	5.53	1702	5.89	1747	6.25	1792	6.62	1835	6.98	1877	7.35
3189	3400	1532	4.84	1584	5.23	1633	5.61	1681	5.99	1727	6.36	1773	6.76	1816	7.13	1859	7.52	1901	7.91
3377	3600	1562	5.28	1612	5.67	1661	6.07	1708	6.47	1754	6.88	1799	7.28	1842	7.68	1885	8.10	1926	8.50
3564	3800	1592	5.74	1642	6.15	1689	6.55	1736	6.97	1781	7.40	1826	7.83	1869	8.26	1911	8.69	1951	9.10
3752	4000	1624	6.27	1672	6.67	1719	7.08	1765	7.52	1810	7.96	1853	8.40	1896	8.86	1937	9.30	1978	9.76
3940	4200	1657	6.84	1704	7.25	1750	7.67	1795	8.10	1839	8.55	1882	9.01	1924	9.48	1965	9.95	2005	10.42
4127	4400	1690	7.45	1737	7.88	1782	8.30	1826	8.74	1869	9.19	1911	9.65	1953	10.14	1993	10.62	2033	11.11
4315	4600	1725	8.11	1770	8.54	1815	8.99	1858	9.43	1900	9.89	1942	10.36	1982	10.84	2022	11.33	2061	11.83
4502	4800	1760	8.81	1804	9.25	1848	9.71	1891	10.18	1932	10.64	1973	11.12	2013	11.60	2052	12.10	2091	12.62
4690	5000	1797	9.58	1840	10.03	1882	10.49	1924	10.97	1965	11.45	2005	11.93	2045	12.44	2083	12.93	2121	13.45
4878	5200	1835	10.40	1876	10.85	1918	11.34	1959	11.83	1999	12.32	2038	12.81	2077	13.32	2115	13.83	2152	14.34
5065	5400	1873	11.25	1914	11.74	1954	12.22	1994	12.73	2033	13.22	2072	13.74	2110	14.25	2147	14.77	2184	15.30
5253	5600	1913	12.19	1952	12.67	1991	13.17	2030	13.68	2068	14.19	2106	14.72	2144	15.26	2181	15.80	2217	16.33
5440	5800	1954	13.20	1992	13.69	2029	14.17	2067	14.70	2104	15.22	2142	15.77	2178	16.30	2214	16.84	2250	17.40
CFM	OV	10" SP		11" SP		12" SP		13" SP		14" SP		15" SP		16" SP		17" SP		18" SP	
		RPM	BHP	RPM	BHP	RPM	BHP	RPM	BHP	RPM	BHP	RPM	BHP	RPM	BHP	RPM	BHP	RPM	BHP
2439	2600	1895	6.43	1976	7.07	2055	7.74	2131	8.42	2206	9.13	2279	9.86	2349	10.59	2419	11.36		
2626	2800	1916	6.97	1995	7.63	2072	8.31	2146	9.00	2219	9.72	2290	10.46	2359	11.21	2427	11.99	2494	12.79
2814	3000	1937	7.52	2016	8.23	2091	8.93	2165	9.66	2236	10.39	2305	11.14	2373	11.91	2439	12.69	2504	13.49
3002	3200	1959	8.10	2038	8.85	2113	9.60	2185	10.35	2255	11.11	2323	11.88	2389	12.66	2454	13.46	2518	14.28
3189	3400	1982	8.69	2059	9.47	2134	10.27	2206	11.07	2276	11.88	2343	12.67	2408	13.48	2472	14.30	2535	15.14
3377	3600	2006	9.32	2082	10.13	2157	10.98	2228	11.81	2298	12.67	2364	13.50	2429	14.35	2492	15.20		
3564	3800	2031	9.97	2107	10.84	2180	11.70	2251	12.58	2319	13.46	2386	14.35	2451	15.25	2514	16.15		
3752	4000	2056	10.65	2132	11.56	2204	12.46	2274	13.37	2342	14.29	2408	15.22	2473	16.17	2535	17.10		
3940	4200	2083	11.37	2157	12.30	2229	13.25	2299	14.21	2366	15.16	2431	16.12	2495	17.10				
4127	4400	2110	12.11	2184	13.10	2255	14.08	2324	15.07	2391	16.07	2455	17.06	2518	18.06				
4315	4600	2137	12.86	2211	13.91	2281	14.93	2350	15.97	2416	17.00	2480	18.04						
4502	4800	2166	13.67	2238	14.73	2308	15.81	2376	16.90	2442	17.98	2506	19.06						
4690	5000	2195	14.51	2267	15.62	2336	16.73	2403	17.85	2468	18.97	2532	20.11						
4878	5200	2225	15.42	2296	16.54	2364	17.67	2431	18.85	2496	20.03								
5065	5400	2256	16.39	2325	17.50	2393	18.67	2459	19.87	2523	21.08								
5253	5600	2288	17.44	2356	18.56	2423	19.74	2488	20.95										
5440	5800	2320	18.53	2387	19.66	2453	20.85	2517	22.07										
5628	6000	2353	19.70	2420	20.87	2485	22.07												
5816	6200	2386	20.92	2452	22.11	2516	23.32												
6003	6400	2421	22.23	2485	23.42														

Performance shown is with inlet and outlet ducts.
 BHP shown does not include drive losses.
 Underlined figures indicate maximum static efficiency.

Performance Data

RBF 29

Outlet Area = 1.6 Sq. Ft.

Wheel Dia. = 29.625

Tip Speed = 7.756 x RPM

CFM	OV	0.5" SP		1" SP		1.5" SP		2" SP		2.5" SP		3" SP		3.5" SP		4" SP		4.5" SP	
		RPM	BHP	RPM	BHP	RPM	BHP	RPM	BHP	RPM	BHP	RPM	BHP	RPM	BHP	RPM	BHP	RPM	BHP
1600	1000	361	0.23	472	0.43	560	0.63	637	0.85	708	1.10								
1920	1200	384	0.31	490	0.54	576	0.77	650	1.02	<u>717</u>	<u>1.27</u>			839	1.84				
2240	1400	408	0.40	510	0.66	593	0.93	666	1.20	731	<u>1.48</u>	791	1.77	847	<u>2.07</u>	901	2.40	952	2.73
2560	1600	435	0.52	531	0.79	613	1.10	683	1.41	747	1.72	806	2.04	860	<u>2.36</u>	912	<u>2.70</u>	961	<u>3.04</u>
2880	1800	465	0.68	555	0.96	633	1.29	703	1.64	765	1.98	823	2.34	877	2.70	927	<u>3.06</u>	975	<u>3.43</u>
3200	2000	496	0.86	580	1.17	655	1.50	723	1.89	784	2.27	841	2.66	893	3.04	943	3.44	991	3.85
3520	2200	528	1.08	607	1.41	679	1.76	744	2.15	804	2.57	860	3.00	912	3.42	961	3.85	1007	4.28
3840	2400	560	1.32	636	1.69	704	2.06	767	2.46	826	2.91	880	3.36	931	3.82	979	4.28	1025	4.75
4160	2600	593	1.61	666	2.01	730	2.40	791	2.82	848	3.28	901	3.76	952	4.27	999	4.76	1044	5.26
4480	2800	626	1.93	697	2.38	758	2.79	817	3.24	872	3.70	924	4.20	973	4.72	1019	5.25	1064	5.80
4800	3000	660	2.31	729	2.79	788	3.24	843	3.69	896	4.17	947	4.69	995	5.23	1041	5.79	1084	6.35
5120	3200	693	2.72	761	3.25	818	3.73	871	4.21	922	4.71	971	5.24	1018	5.79	1063	6.37	1106	6.97
5440	3400	728	3.19	794	3.77	850	4.29	900	4.78	949	5.31	996	5.84	1042	6.41	1086	7.00	1128	7.61
5760	3600	762	3.70	826	4.32	881	4.89	930	5.42	977	5.96	1023	6.53	1067	7.11	1110	7.71	1151	8.33
6080	3800	797	4.28	859	4.94	913	5.55	961	6.12	1006	6.68	1050	7.26	1093	7.87	1135	8.49	1175	9.12
6400	4000	832	4.91	892	5.61	945	6.27	993	6.90	1036	7.47	1078	8.06	1120	8.70	1160	9.33	1200	9.99
6720	4200	867	5.60	926	6.36	978	7.07	1025	7.73	1067	8.34	1108	8.96	1147	9.58	1187	10.26	1225	10.92
7040	4400	903	6.37	959	7.15	1010	7.90	1057	8.63	1098	9.26	1138	9.92	1176	10.56	1214	11.24	1251	11.93
7360	4600	939	7.21	993	8.02	1043	8.82	1089	9.58	1130	10.28	1169	10.96	1206	11.63	1242	12.31	1278	13.02
7680	4800	974	8.09	1028	8.98	1076	9.80	1121	10.61	1162	11.36	1200	12.07	1236	12.76	1271	13.46	1306	14.20
CFM	OV	5" SP		5.5" SP		6" SP		6.5" SP		7" SP		7.5" SP		8" SP		8.5" SP		9" SP	
		RPM	BHP	RPM	BHP	RPM	BHP	RPM	BHP	RPM	BHP	RPM	BHP	RPM	BHP	RPM	BHP	RPM	BHP
2560	1600	1008	<u>3.40</u>	1054	3.78	1099	4.17												
2880	1800	1020	<u>3.79</u>	1064	4.18	1107	<u>4.58</u>	1149	5.00	1189	5.42	1229	5.86	1267	6.30				
3200	2000	1035	<u>4.24</u>	1078	4.65	1120	<u>5.07</u>	1160	5.49	1199	5.92	1237	<u>6.37</u>	1275	6.83	1311	7.30	1347	7.78
3520	2200	1052	<u>4.73</u>	1094	5.16	1135	<u>5.61</u>	1174	<u>6.05</u>	1212	<u>6.50</u>	1249	<u>6.96</u>	1285	<u>7.42</u>	1321	<u>7.91</u>	1356	<u>8.41</u>
3840	2400	1069	5.23	1111	5.70	1151	6.18	1190	6.66	1228	7.15	1264	<u>7.63</u>	1299	8.11	1334	8.61	1368	9.12
4160	2600	1087	5.76	1128	6.26	1168	6.77	1207	7.30	1244	7.81	1280	8.33	1315	8.85	1349	<u>9.37</u>	1382	<u>9.90</u>
4480	2800	1106	6.33	1147	6.87	1186	7.41	1224	7.95	1261	8.51	1297	9.07	1332	9.63	1366	10.20	1398	10.74
4800	3000	1126	6.93	1167	7.52	1205	8.08	1243	8.67	1279	9.25	1314	9.83	1349	10.43	1382	11.02	1415	11.62
5120	3200	1147	7.57	1187	8.19	1225	8.80	1262	9.41	1298	10.03	1333	10.65	1367	11.27	1400	11.90	1432	12.52
5440	3400	1168	8.24	1208	8.90	1245	9.54	1282	10.20	1318	10.86	1352	11.50	1386	12.17	1418	12.81	1450	13.47
5760	3600	1191	8.98	1229	9.64	1266	10.32	1303	11.03	1338	11.72	1372	12.40	1405	13.09	1437	13.77	1469	14.47
6080	3800	1214	9.78	1251	10.44	1288	11.15	1324	11.88	1359	12.62	1392	13.33	1425	14.06	1457	14.78	1488	15.50
6400	4000	1238	10.66	1275	11.35	1311	12.06	1346	12.80	1380	13.55	1413	14.30	1446	15.08	1478	15.86	1509	16.63
6720	4200	1262	11.60	1299	12.32	1334	13.04	1368	13.77	1402	14.55	1435	15.34	1467	16.13	1498	16.92	1529	17.74
7040	4400	1288	12.65	1323	13.36	1358	14.10	1392	14.86	1425	15.64	1457	16.43	1489	17.25	1520	18.08	1550	18.91
7360	4600	1314	13.76	1349	14.51	1383	15.27	1416	16.03	1448	16.80	1480	17.61	1511	18.43	1542	19.30	1572	20.16
7680	4800	1341	14.96	1375	15.73	1408	16.49	1441	17.29	1473	18.10	1504	18.90	1535	19.75	1564	20.57	1594	21.46
8000	5000	1369	16.26	1402	17.04	1434	17.81	1466	18.62	1498	19.47	1528	20.27	1558	21.11	1588	21.99	1617	22.87
8320	5200	1397	17.61	1429	18.41	1461	19.24	1492	20.06	1523	20.91	1553	21.75	1583	22.63	1612	23.50	1641	24.41
8640	5400	1427	19.11	1458	19.92	1488	20.73	1519	21.60	1549	22.45	1579	23.34	1608	24.21	1637	25.12	1665	26.02
8960	5600	1457	20.68	1487	21.51	1517	22.36	1546	23.20	1576	24.11	1605	25.00	1633	25.87	1662	26.83	1689	27.71
9280	5800	1487	22.33	1517	23.21	1546	24.08	1574	24.92	1603	25.84	1632	26.78	1660	27.70	1687	28.60	1715	29.58
CFM	OV	10" SP		11" SP		12" SP		13" SP		14" SP		15" SP		16" SP		17" SP		18" SP	
		RPM	BHP	RPM	BHP	RPM	BHP	RPM	BHP	RPM	BHP	RPM	BHP	RPM	BHP	RPM	BHP	RPM	BHP
4160	2600	1447	<u>10.98</u>	1508	<u>12.06</u>	1569	<u>13.21</u>	1627	<u>14.37</u>	1684	15.58	1740	16.84	1794	18.11	1847	19.41		
4480	2800	1462	<u>11.88</u>	1523	<u>13.02</u>	1581	<u>14.17</u>	1638	<u>15.36</u>	1694	<u>16.60</u>	1748	17.85	1801	19.15	1853	20.48		
4800	3000	1478	12.82	1538	14.02	1596	15.24	1652	16.47	1706	17.71	1759	18.99	1811	20.31	1862	21.66	1904	21.84
5120	3200	1495	13.81	1555	15.09	1612	16.36	1667	17.64	1721	18.95	1773	20.26	1824	21.61	1873	22.95	1912	23.05
5440	3400	1512	14.81	1571	16.15	1629	17.53	1684	18.89	1737	20.25	1788	21.61	1838	22.99	1887	24.40	1935	25.83
5760	3600	1530	15.87	1589	17.28	1645	18.69	1700	20.13	1753	21.58	1804	23.02	1854	24.48	1902	25.92		
6080	3800	1549	16.98	1607	18.45	1663	19.94	1717	21.43	1770	22.96	1821	24.49	1870	25.99	1918	27.51		
6400	4000	1568	18.13	1626	19.68	1681	21.21	1735	22.79	1787	24.36	1837	25.93	1887	27.56	1935	29.17		
6720	4200	1588	19.34	1645	20.94	1700	22.56	1753	24.18	1805	25.84	1855	27.48	1904	29.16				
7040	4400	1609	20.61	1665	22.28	1720	23.98	1773	25.69	1824	27.39	1873	29.07	1921	30.78				
7360	4600	1630	21.91	1686	23.67	1740	25.44	1792	27.19	1843	28.97	1892	30.74						
7680	4800	1651	23.24	1707	25.10	1760	26.92	1812	28.77	1862	30.59								
8000	5000	1673	24.67	1728	26.56	1781	28.47	1833	30.42	1883	32.35	1931	34.24						
8320	5200	1696	26.21	1750	28.12	1803	30.11	1854	32.10	1903	34.08								
8640	5400	1720	27.88	1773	29.80	1825	31.80	1875	33.82	1924	35.89								
8960	5600	1744	29.64	1796	31.55	1847	33.56	1897	35.65										
9280	5800	1768	31.48	1820	33.46	1870	35.46	1919	37.55										
9600	6000	1793	33.46	1844	35.45	1894	37.51												
9920	6200	1818	35.51	1869	37.58	1918	39.66												
10240	6400	1844	37.70	1894	39.80														

Performance shown is with inlet and outlet ducts.
 BHP shown does not include drive losses.
 Underlined figures indicate maximum static efficiency.

Performance Data

RBF 33

Outlet Area = 1.982 Sq. Ft.

Wheel Dia. = 33

Tip Speed = 8.639 x RPM

CFM	OV	0.5" SP		1" SP		1.5" SP		2" SP		2.5" SP		3" SP		3.5" SP		4" SP		4.5" SP	
		RPM	BHP	RPM	BHP	RPM	BHP	RPM	BHP	RPM	BHP	RPM	BHP	RPM	BHP	RPM	BHP	RPM	BHP
1982	1000	319	0.27	417	0.49	498	0.73												
2378	1200	340	0.36	432	0.61	509	0.88	577	1.17	640	1.48								
2775	1400	363	0.47	450	0.74	524	1.05	589	1.37	648	1.71	704	2.06	757	2.43				
3171	1600	386	0.60	470	0.91	541	1.25	603	1.60	661	1.97	714	2.34	764	2.73	812	3.14	858	3.56
3568	1800	411	0.77	492	1.11	560	1.47	620	1.85	675	2.25	727	2.66	776	3.09	822	3.52	866	3.96
3964	2000	435	0.96	515	1.35	580	1.73	639	2.14	692	2.57	742	3.01	789	3.46	834	3.92	877	4.40
4360	2200	459	1.17	538	1.61	602	2.04	659	2.48	711	2.93	759	3.39	805	3.88	848	4.37	890	4.80
4757	2400	483	1.41	563	1.93	625	2.38	680	2.85	730	3.32	777	3.81	822	4.33	864	4.85	905	5.47
5153	2600	507	1.68	587	2.27	648	2.77	702	3.27	751	3.78	797	4.30	840	4.83	882	5.39	921	5.95
5550	2800	532	2.00	612	2.66	672	3.20	725	3.74	773	4.28	818	4.84	860	5.39	900	5.96	939	6.56
5946	3000	558	2.36	635	3.05	697	3.69	748	4.26	796	4.85	839	5.41	881	6.02	920	6.61	958	7.23
6342	3200	583	2.75	659	3.50	721	4.21	772	4.83	819	5.45	862	6.07	902	6.68	941	7.32	978	7.96
6739	3400	610	3.21	684	4.01	745	4.77	796	5.45	842	6.11	885	6.78	924	7.41	962	8.08	998	8.74
7135	3600	636	3.70	708	4.55	769	5.38	821	6.14	866	6.84	908	7.53	947	8.22	984	8.91	1020	9.62
7532	3800	663	4.25	733	5.15	793	6.03	845	6.86	890	7.62	931	8.34	970	9.08	1007	9.82	1042	10.55
7928	4000	691	4.87	758	5.80	817	6.73	870	7.66	915	8.48	955	9.24	993	9.99	1030	10.78	1065	11.57
8324	4200	719	5.54	783	6.50	841	7.48	894	8.48	939	9.37	980	10.22	1017	11.00	1053	11.81	1087	12.61
8721	4400	747	6.27	809	7.29	866	8.31	918	9.36	964	10.35	1004	11.23	1042	12.10	1077	12.93	1111	13.79
9117	4600	775	7.06	835	8.13	891	9.20	941	10.26	988	11.35	1029	12.33	1066	13.23	1101	14.12	1134	14.99
9514	4800	804	7.94	861	9.03	916	10.16	966	11.29	1012	12.42	1053	13.46	1091	14.47	1125	15.38	1158	16.30
CFM	OV	5" SP		5.5" SP		6" SP		6.5" SP		7" SP		7.5" SP		8" SP		8.5" SP		9" SP	
		RPM	BHP	RPM	BHP	RPM	BHP	RPM	BHP	RPM	BHP	RPM	BHP	RPM	BHP	RPM	BHP	RPM	BHP
3171	1600	903	4.00																
3568	1800	908	4.41	950	4.89	990	5.37												
3964	2000	918	4.88	958	5.38	996	5.87	1034	6.40	1070	6.91	1106	7.45						
4360	2200	930	5.38	969	5.91	1006	6.44	1042	6.97	1078	7.54	1112	8.09	1146	8.66	1179	9.24	1212	9.84
4757	2400	944	5.94	982	6.49	1018	7.04	1054	7.63	1088	8.20	1121	8.77	1154	9.37	1186	9.97	1218	10.60
5153	2600	959	6.52	996	7.11	1032	7.70	1067	8.31	1100	8.90	1133	9.52	1165	10.15	1196	10.77	1227	11.42
5550	2800	976	7.16	1012	7.78	1047	8.41	1081	9.04	1114	9.67	1146	10.32	1178	10.99	1208	11.63	1238	12.29
5946	3000	994	7.85	1029	8.49	1064	9.17	1097	9.83	1129	10.49	1161	11.18	1191	11.84	1222	12.55	1251	13.24
6342	3200	1013	8.60	1048	9.28	1081	9.95	1114	10.66	1145	11.34	1176	12.06	1206	12.77	1236	13.50	1265	14.23
6739	3400	1033	9.42	1067	10.12	1100	10.83	1132	11.55	1163	12.28	1193	13.02	1223	13.78	1252	14.53	1280	15.28
7135	3600	1054	10.32	1087	11.04	1119	11.76	1151	12.52	1181	13.26	1211	14.04	1240	14.81	1268	15.58	1296	16.38
7532	3800	1076	11.30	1108	12.03	1140	12.81	1170	13.55	1200	14.32	1230	15.14	1258	15.92	1286	16.73	1314	17.58
7928	4000	1098	12.34	1130	13.12	1161	13.90	1191	14.69	1220	15.48	1249	16.30	1277	17.12	1305	17.97	1332	18.82
8324	4200	1120	13.43	1152	14.26	1182	15.05	1212	15.89	1241	16.72	1269	17.55	1297	18.41	1324	19.27	1351	20.16
8721	4400	1143	14.61	1174	15.45	1205	16.34	1234	17.19	1262	18.03	1290	18.91	1317	19.77	1344	20.67	1370	21.56
9117	4600	1166	15.87	1197	16.76	1227	17.65	1256	18.55	1284	19.44	1311	20.32	1338	21.23	1364	22.13	1390	23.07
9514	4800	1190	17.24	1220	18.13	1250	19.08	1279	20.02	1306	20.91	1333	21.84	1360	22.81	1386	23.76	1411	24.69
9910	5000	1214	18.67	1244	19.62	1273	20.57	1302	21.56	1329	22.50	1356	23.48	1382	24.45	1407	25.39	1432	26.37
10306	5200	1238	20.19	1268	21.19	1296	22.14	1324	23.13	1352	24.17	1379	25.20	1404	26.16	1430	27.21	1454	28.18
10703	5400	1262	21.77	1292	22.84	1320	23.84	1348	24.89	1375	25.92	1401	26.94	1427	28.00	1452	29.05	1477	30.12
11099	5600	1287	23.49	1316	24.56	1344	25.62	1372	26.72	1398	27.75	1424	28.82	1450	29.93	1475	31.02	1499	32.09
11496	5800	1311	25.23	1341	26.42	1369	27.54	1396	28.64	1422	29.72	1448	30.84	1473	31.94	1498	33.08	1522	34.20
CFM	OV	10" SP		11" SP		12" SP		13" SP		14" SP		15" SP		16" SP		17" SP		18" SP	
		RPM	BHP	RPM	BHP	RPM	BHP	RPM	BHP	RPM	BHP	RPM	BHP	RPM	BHP	RPM	BHP	RPM	BHP
5153	2600	1287	12.73	1345	14.08	1401	15.44	1456	16.85										
5550	2800	1297	13.67	1353	15.05	1408	16.48	1461	17.93	1513	19.41	1564	20.92						
5946	3000	1308	14.65	1363	16.08	1417	17.58	1469	19.08	1519	20.58	1569	22.16	1618	23.77	1665	25.36		
6342	3200	1321	15.70	1375	17.19	1428	18.74	1479	20.30	1528	21.86	1577	23.49	1624	25.12	1671	26.81	1716	28.47
6739	3400	1335	16.81	1389	18.40	1440	19.96	1490	21.57	1539	23.22	1586	24.86	1633	26.58	1678	28.27	1723	30.03
7135	3600	1350	17.97	1403	19.62	1454	21.28	1503	22.93	1551	24.63	1598	26.37	1643	28.08	1688	29.87	1731	31.62
7532	3800	1367	19.24	1418	20.91	1468	22.62	1517	24.37	1564	26.11	1610	27.89	1655	29.70	1699	31.52		
7928	4000	1384	20.53	1435	22.30	1484	24.07	1532	25.88	1578	27.66	1624	29.53	1668	31.38	1711	33.24		
8324	4200	1402	21.90	1452	23.72	1500	25.54	1547	27.40	1593	29.29	1638	31.21	1682	33.14	1725	35.10		
8721	4400	1421	23.38	1470	25.23	1518	27.15	1564	29.05	1609	30.99	1653	32.96	1697	35.00	1739	36.99		
9117	4600	1440	24.92	1489	26.85	1536	28.80	1582	30.80	1626	32.78	1669	34.78	1712	36.87				
9514	4800	1460	26.58	1508	28.54	1555	30.57	1600	32.60	1644	34.67	1687	36.77	1728	38.83				
9910	5000	1481	28.37	1528	30.36	1574	32.41	1619	34.51	1662	36.61	1704	38.73						
10306	5200	1502	30.21	1549	32.31	1594	34.39	1638	36.51	1681	38.68	1723	40.89						
10703	5400	1524	32.20	1570	34.33	1614	36.44	1658	38										

Performance Data

RBF 36

Outlet Area = 2.43 Sq. Ft.

Wheel Dia. = 36.5

Tip Speed = 9.556 x RPM

CFM	OV	0.5" SP		1" SP		1.5" SP		2" SP		2.5" SP		3" SP		3.5" SP		4" SP		4.5" SP			
		RPM	BHP	RPM	BHP	RPM	BHP	RPM	BHP	RPM	BHP	RPM	BHP	RPM	BHP	RPM	BHP	RPM	BHP	RPM	BHP
2430	1000	289	0.33	377	0.60	450	0.90														
2916	1200	308	0.44	391	0.75	460	1.08	522	1.44	579	1.82										
3402	1400	328	0.57	407	0.91	474	1.29	533	1.69	586	2.09	636	2.52	684	2.97						
3888	1600	349	0.74	426	1.13	489	1.53	546	1.96	598	2.41	646	2.88	691	3.35	734	3.84	776	4.37		
4374	1800	372	0.95	445	1.37	506	1.80	561	2.27	611	2.76	658	3.27	701	3.77	743	4.30	783	4.85		
4860	2000	394	1.18	466	1.65	525	2.13	578	2.63	626	3.15	671	3.69	714	4.25	754	4.80	793	5.39		
5346	2200	415	1.43	487	1.98	545	2.51	596	3.04	643	3.59	687	4.17	728	4.76	767	5.36	805	5.98		
5832	2400	437	1.73	509	2.36	566	2.93	615	3.50	661	4.09	703	4.68	743	5.30	782	5.96	818	6.60		
6318	2600	459	2.07	531	2.78	587	3.41	635	4.01	680	4.65	721	5.27	760	5.92	798	6.62	833	7.29		
6804	2800	482	2.46	554	3.26	608	3.93	656	4.59	700	5.27	740	5.93	778	6.62	815	7.33	850	8.06		
7290	3000	505	2.90	575	3.76	630	4.52	677	5.23	720	5.94	760	6.67	797	7.38	832	8.10	867	8.88		
7776	3200	528	3.39	597	4.31	653	5.18	699	5.94	741	6.69	780	7.45	816	8.20	851	8.98	885	9.78		
8262	3400	552	3.94	619	4.92	675	5.88	721	6.71	762	7.51	801	8.33	837	9.13	871	9.94	903	10.73		
8748	3600	576	4.56	641	5.59	696	6.61	743	7.55	784	8.41	821	9.23	857	10.09	891	10.96	923	11.81		
9234	3800	601	5.25	664	6.34	718	7.41	765	8.44	806	9.38	843	10.26	878	11.16	911	12.04	943	12.96		
9720	4000	626	6.00	686	7.12	740	8.28	787	9.40	828	10.41	865	11.37	899	12.29	932	13.24	963	14.17		
10206	4200	651	6.82	709	8.00	762	9.22	809	10.42	850	11.52	887	12.55	921	13.54	953	14.51	984	15.50		
10692	4400	676	7.70	733	8.98	784	10.22	831	11.51	872	12.69	909	13.80	943	14.86	975	15.90	1005	16.91		
11178	4600	702	8.69	756	10.00	807	11.33	852	12.62	894	13.94	931	15.13	965	16.27	996	17.33	1026	18.40		
11664	4800	728	9.76	780	11.12	829	12.47	874	13.85	916	15.26	953	16.54	987	17.75	1019	18.94	1048	20.02		
CFM	OV	5" SP		5.5" SP		6" SP		6.5" SP		7" SP		7.5" SP		8" SP		8.5" SP		9" SP			
		RPM	BHP	RPM	BHP	RPM	BHP	RPM	BHP	RPM	BHP	RPM	BHP	RPM	BHP	RPM	BHP	RPM	BHP	RPM	BHP
3888	1600	816	4.89																		
4374	1800	821	5.40	859	5.99	895	6.58														
4860	2000	830	5.98	866	6.58	901	7.21	935	7.84	968	8.49	1000	9.13								
5346	2200	841	6.60	876	7.24	910	7.90	943	8.57	975	9.24	1006	9.92	1036	10.61	1066	11.32	1096	12.06		
5832	2400	854	7.29	888	7.96	921	8.65	953	9.34	984	10.05	1014	10.76	1044	11.50	1073	12.24	1101	12.97		
6318	2600	868	8.01	901	8.72	933	9.44	965	10.19	995	10.92	1025	11.69	1054	12.45	1082	13.22	1110	14.01		
6804	2800	883	8.79	916	9.56	947	10.31	978	11.09	1008	11.88	1037	12.67	1065	13.45	1093	14.27	1120	15.09		
7290	3000	900	9.65	931	10.42	962	11.23	992	12.04	1021	12.86	1050	13.71	1078	14.55	1105	15.39	1132	16.26		
7776	3200	917	10.57	948	11.38	978	12.21	1007	13.05	1036	13.93	1064	14.80	1091	15.67	1118	16.57	1144	17.45		
8262	3400	935	11.58	966	12.45	995	13.28	1024	14.17	1052	15.07	1079	15.96	1106	16.89	1132	17.81	1158	18.75		
8748	3600	954	12.69	984	13.57	1013	14.46	1041	15.35	1069	16.30	1096	17.25	1122	18.19	1147	19.11	1173	20.13		
9234	3800	973	13.85	1003	14.79	1031	15.70	1059	16.65	1086	17.59	1113	18.59	1138	19.53	1164	20.57	1188	21.53		
9720	4000	993	15.12	1022	16.08	1050	17.04	1077	18.00	1104	19.01	1130	20.00	1156	21.04	1180	22.02	1205	23.09		
10206	4200	1014	16.51	1042	17.48	1070	18.51	1097	19.53	1123	20.54	1148	21.54	1173	22.58	1198	23.66	1222	24.72		
10692	4400	1035	17.98	1063	19.01	1090	20.04	1116	21.07	1142	22.14	1167	23.20	1192	24.30	1216	25.37	1240	26.49		
11178	4600	1055	19.48	1084	20.63	1111	21.72	1137	22.80	1162	23.88	1187	24.99	1211	26.09	1234	27.16	1258	28.34		
11664	4800	1077	21.17	1104	22.27	1131	23.41	1157	24.56	1182	25.69	1207	26.87	1230	27.96	1254	29.16	1277	30.33		
12150	5000	1098	22.90	1126	24.11	1152	25.26	1178	26.47	1203	27.66	1227	28.83	1251	30.05	1274	31.24	1296	32.40		
12636	5200	1120	24.77	1147	25.99	1173	27.20	1199	28.47	1223	29.65	1248	30.96	1271	32.16	1294	33.41	1316	34.63		
13122	5400	1143	26.81	1169	28.03	1195	29.31	1220	30.57	1244	31.81	1268	33.10	1291	34.36	1314	35.67	1336	36.95		
13608	5600	1165	28.87	1191	30.16	1217	31.52	1241	32.77	1265	34.07	1289	35.42	1312	36.74	1335	38.12	1357	39.45		
14094	5800	1187	31.03	1213	32.40	1239	33.82	1263	35.14	1287	36.51	1310	37.85	1333	39.23	1355	40.58	1377	41.97		
CFM	OV	10" SP		11" SP		12" SP		13" SP		14" SP		15" SP		16" SP		17" SP		18" SP			
		RPM	BHP	RPM	BHP	RPM	BHP	RPM	BHP	RPM	BHP	RPM	BHP	RPM	BHP	RPM	BHP	RPM	BHP	RPM	BHP
6318	2600	1164	15.61	1216	17.24	1267	18.94	1316	20.63												
6804	2800	1172	16.72	1223	18.42	1273	20.19	1321	21.97	1368	23.79	1414	25.64								
7290	3000	1183	17.96	1233	19.74	1281	21.53	1328	23.37	1374	25.25	1419	27.18	1463	29.14	1506	31.11				
7776	3200	1195	19.26	1244	21.11	1291	22.96	1337	24.86	1382	26.81	1426	28.80	1469	30.82	1511	32.86	1552	34.92		
8262	3400	1208	20.64	1256	22.54	1303	24.51	1348	26.47	1392	28.48	1435	30.52	1476	32.53	1518	34.69	1558	36.81		
8748	3600	1222	22.10	1269	24.07	1315	26.09	1360	28.17	1403	30.22	1445	32.32	1486	34.44	1526	36.58	1566	38.81		
9234	3800	1236	23.57	1283	25.67	1328	27.75	1372	29.88	1415	32.05	1456	34.19	1497	36.43	1536	38.61				
9720	4000	1252	25.18	1298	27.35	1342	29.50	1385	31.69	1428	33.98	1469	36.23	1509	38.51	1548	40.81				
10206	4200	1269	26.92	1314	29.13	1357	31.34	1400	33.66	1441	35.94	1482	38.31	1521	40.62	1560	43.03				
10692	4400	1286	28.72	1330	30.97	1373	33.29	1415	35.66	1456	38.06	1495	40.41	1534	42.85						
11178	4600	1303	30.60	1347	32.95	1390	35.37	1431	37.78	1471	40.22	1510	42.69	1548	45.18						
11664	4800	1321	32.63	1365	35.08	1407	37.53	1447													

Performance Data

RBF 40

Outlet Area = 2.914 Sq. Ft.

Wheel Dia. = 40

Tip Speed = 10,472 x RPM

CFM	OV	0.5" SP		1" SP		1.5" SP		2" SP		2.5" SP		3" SP		3.5" SP		4" SP		4.5" SP			
		RPM	BHP	RPM	BHP	RPM	BHP	RPM	BHP	RPM	BHP	RPM	BHP	RPM	BHP	RPM	BHP	RPM	BHP	RPM	BHP
2914	1000	263	0.39	344	0.72	411	1.08														
3497	1200	281	0.53	357	0.90	420	1.29	476	1.72	528	2.18										
4080	1400	299	0.69	372	1.10	432	1.55	486	2.02	535	2.51	581	3.03	624	3.56						
4662	1600	319	0.89	388	1.34	446	1.83	498	2.35	545	2.89	589	3.44	630	4.01	670	4.62	708	5.23		
5245	1800	339	1.13	406	1.64	462	2.17	512	2.73	557	3.30	600	3.91	640	4.53	678	5.17	714	5.81		
5828	2000	359	1.41	425	1.98	479	2.56	527	3.15	571	3.77	612	4.42	651	5.08	688	5.76	723	6.45		
6411	2200	379	1.72	444	2.37	497	3.00	543	3.63	586	4.29	626	4.98	664	5.70	700	6.43	734	7.16		
6994	2400	398	2.07	464	2.82	516	3.51	561	4.19	603	4.90	642	5.63	678	6.36	713	7.14	747	7.94		
7576	2600	419	2.49	485	3.35	535	4.08	579	4.80	620	5.56	658	6.33	694	7.12	728	7.93	760	8.75		
8159	2800	439	2.94	505	3.90	555	4.72	598	5.50	638	6.30	675	7.11	710	7.94	743	8.78	775	9.65		
8742	3000	460	3.46	524	4.49	575	5.43	617	6.25	657	7.13	693	7.98	727	8.85	759	9.71	790	10.61		
9325	3200	482	4.07	544	5.16	595	6.19	637	7.10	676	8.03	711	8.91	745	9.85	776	10.75	807	11.71		
9908	3400	503	4.72	564	5.88	615	7.03	657	8.02	695	9.00	730	9.95	763	10.92	794	11.89	824	12.88		
10490	3600	525	5.45	584	6.68	635	7.92	678	9.06	715	10.07	749	11.07	782	12.11	812	13.10	842	14.17		
11073	3800	548	6.28	605	7.57	655	8.89	698	10.13	735	11.23	769	12.31	801	13.38	831	14.44	860	15.53		
11656	4000	570	7.16	626	8.55	675	9.93	718	11.27	755	12.47	789	13.63	820	14.73	850	15.86	879	17.02		
12239	4200	593	8.14	647	9.60	694	11.00	737	12.44	775	13.79	809	15.04	840	16.22	869	17.38	897	18.55		
12822	4400	616	9.21	668	10.74	715	12.24	757	13.74	795	15.19	829	16.54	860	17.81	889	19.04	917	20.29		
13404	4600	640	10.41	689	11.96	735	13.52	777	15.12	815	16.68	849	18.13	880	19.49	909	20.80	936	22.06		
13987	4800	663	11.65	711	13.31	756	14.94	797	16.59	835	18.26	869	19.81	900	21.26	929	22.67	956	24.01		
CFM	OV	5" SP		5.5" SP		6" SP		6.5" SP		7" SP		7.5" SP		8" SP		8.5" SP		9" SP			
		RPM	BHP	RPM	BHP	RPM	BHP	RPM	BHP	RPM	BHP	RPM	BHP	RPM	BHP	RPM	BHP	RPM	BHP	RPM	BHP
4662	1600	745	5.88																		
5245	1800	749	6.48	783	7.17	817	7.90														
5828	2000	757	7.16	790	7.89	822	8.64	853	9.40	883	10.17	913	10.97								
6411	2200	767	7.91	799	8.68	830	9.46	860	10.26	889	11.06	918	11.91	946	12.75	973	13.59	1000	14.46		
6994	2400	779	8.73	810	9.54	840	10.36	869	11.19	898	12.06	925	12.90	952	13.77	979	14.68	1005	15.58		
7576	2600	792	9.61	822	10.46	851	11.31	880	12.21	908	13.11	935	14.01	961	14.91	987	15.84	1012	16.77		
8159	2800	806	10.55	835	11.43	864	12.36	892	13.29	919	14.22	946	15.19	972	16.15	997	17.11	1022	18.10		
8742	3000	821	11.57	849	12.48	878	13.48	905	14.44	932	15.45	958	16.44	983	17.42	1008	18.45	1032	19.45		
9325	3200	836	12.65	865	13.66	892	14.64	919	15.67	945	16.69	970	17.71	995	18.77	1020	19.87	1044	20.94		
9908	3400	853	13.89	881	14.91	908	15.95	934	16.99	960	18.08	984	19.12	1009	20.25	1033	21.37	1056	22.46		
10490	3600	870	15.20	897	16.24	924	17.33	950	18.43	975	19.53	999	20.63	1023	21.77	1047	22.96	1070	24.13		
11073	3800	888	16.63	914	17.68	940	18.79	966	19.96	991	21.11	1015	22.27	1038	23.41	1061	24.60	1084	25.83		
11656	4000	906	18.14	932	19.26	958	20.45	983	21.62	1007	22.78	1031	23.99	1054	25.19	1077	26.44	1099	27.67		
12239	4200	925	19.80	951	20.99	976	22.18	1000	23.36	1024	24.59	1047	25.81	1070	27.06	1093	28.37	1115	29.66		
12822	4400	943	21.48	969	22.75	994	24.01	1018	25.26	1042	26.56	1064	27.77	1087	29.10	1109	30.40	1131	31.75		
13404	4600	962	23.33	988	24.67	1013	26.00	1037	27.32	1060	28.62	1082	29.90	1104	31.22	1126	32.59	1147	33.92		
13987	4800	982	25.35	1007	26.69	1032	28.10	1055	29.41	1078	30.78	1100	32.12	1122	33.52	1143	34.87	1164	36.28		
14570	5000	1002	27.48	1026	28.81	1051	30.30	1074	31.68	1097	33.13	1119	34.54	1140	35.92	1161	37.34	1182	38.82		
15153	5200	1022	29.73	1046	31.14	1070	32.61	1093	34.07	1116	35.58	1138	37.07	1159	38.52	1180	40.02	1200	41.46		
15736	5400	1042	32.08	1066	33.57	1090	35.13	1112	36.56	1135	38.16	1157	39.72	1178	41.23	1198	42.70	1219	44.33		
16318	5600	1062	34.54	1086	36.12	1109	37.67	1132	39.28	1154	40.85	1175	42.38	1197	44.07	1217	45.61	1237	47.20		
16901	5800	1082	37.13	1106	38.79	1130	40.53	1152	42.12	1174	43.77	1195	45.38	1216	47.04	1236	48.64	1256	50.30		
CFM	OV	10" SP		11" SP		12" SP		13" SP		14" SP		15" SP		16" SP		17" SP		18" SP			
		RPM	BHP	RPM	BHP	RPM	BHP	RPM	BHP	RPM	BHP	RPM	BHP	RPM	BHP	RPM	BHP	RPM	BHP	RPM	BHP
7576	2600	1062	18.72	1109	20.65	1156	22.71	1201	24.76												
8159	2800	1070	20.09	1116	22.11	1161	24.19	1205	26.33	1248	28.51	1290	30.73								
8742	3000	1079	21.52	1125	23.67	1169	25.83	1212	28.05	1254	30.32	1295	32.62	1335	34.96	1374	37.31				
9325	3200	1090	23.09	1135	25.31	1178	27.54	1220	29.83	1261	32.16	1301	34.53	1340	36.94	1378	39.36	1416	41.88		
9908	3400	1102	24.75	1146	27.04	1188	29.34	1230	31.76	1270	34.16	1309	36.59	1347	39.05	1385	41.61	1421	44.10		
10490	3600	1114	26.44	1158	28.88	1200	31.31	1240	33.71	1280	36.24	1318	38.73	1356	41.32	1392	43.84	1429	46.56		
11073	3800	1128	28.29	1170	30.74	1212	33.32	1252	35.86	1291	38.44	1329	41.06	1366	43.71	1402	46.36				
11656	4000	1142	30.19	1184	32.78	1224	35.35	1264	38.05	1302	40.68	1340	43.43	1376	46.11	1412	48.90				
12239	4200	1157	32.22	1198	34.87	1238	37.58	1277	40.34	1315	43.13	1352	45.94	1388	48.75	1423	51.58				
12822	4400	1173	34.42	1213	37.11	1252	39.86	1291	42.77	1328	45.62	1364	48.47	1400	51.44	1435	54.40				
13404	4600	1189	36.72	1229	39.52	1267	42.31	1305	45.25	1342	48.24	1377	51.13	1413	54.26						
13987	4800	1205	39.12	1245	42.04	1283	44.94	1320	47.91	1356	50.92	1392	54.07	1426	57.11						
14570	5000	1222	41.71	1261	44.67	1299	47.68	1336	50.77	1371	53.78	1406	56.95								
15153	5200	1240	44.50	1278	47.49	1315	50.54	1352	53.73	1387	56.87	1421	60.04								
15736	5400	1258	47.40	1295	50.42	1332	53.61	1368	56.82	1403	60.07										
16318	5600	1276	50.41	1313	53.57	1349	56.78	1385	60.14	1419	63.39										
16901	5800	1294	53.54	1331	56.84	1367	60.19	1402	63.57												
17484	6000	1313	56.92	1350	60.37	1385	63.73	1420	67.25												
18067	6200	1332	60.43	1369	64.02	1404	67.53														
18650	6400	1351	64.																		

Performance Data

RBF 45

Outlet Area = 3.715 Sq. Ft.

Wheel Dia. = 45.125

Tip Speed = 11.814 x RPM

CFM	OV	0.5" SP		1" SP		1.5" SP		2" SP		2.5" SP		3" SP		3.5" SP		4" SP		4.5" SP	
		RPM	BHP	RPM	BHP	RPM	BHP	RPM	BHP	RPM	BHP	RPM	BHP	RPM	BHP	RPM	BHP	RPM	BHP
3715	1000	234	0.50	<u>305</u>	<u>0.92</u>	<u>364</u>	<u>1.37</u>												
4458	1200	249	0.67	316	1.14	<u>372</u>	<u>1.65</u>	422	2.19	468	2.78								
5201	1400	265	0.87	329	1.39	383	1.97	<u>431</u>	<u>2.58</u>	<u>474</u>	<u>3.20</u>	515	3.86	553	4.54				
5944	1600	283	1.14	344	1.71	396	2.34	441	2.99	483	3.67	<u>522</u>	<u>4.38</u>	<u>559</u>	<u>5.13</u>	594	5.89	628	6.68
6687	1800	301	1.45	360	2.09	410	2.77	454	3.48	494	4.22	532	4.99	567	5.76	601	6.58	633	7.40
7430	2000	318	1.79	377	2.53	425	3.26	467	4.01	506	4.80	543	5.65	577	6.48	610	7.35	641	8.22
8173	2200	336	2.20	394	3.03	441	3.83	482	4.64	520	5.48	555	6.35	589	7.28	621	8.21	651	9.13
8916	2400	354	2.66	412	3.62	458	4.49	498	5.36	534	6.23	569	7.17	601	8.11	632	9.09	662	10.11
9659	2600	372	3.18	430	4.27	475	5.22	514	6.14	550	7.10	583	8.05	615	9.07	645	10.09	674	11.16
10402	2800	390	3.76	448	4.98	492	6.01	531	7.04	566	8.05	598	9.05	629	10.10	659	11.20	687	12.30
11145	3000	409	4.45	465	5.74	510	6.92	548	8.01	582	9.07	614	10.15	645	11.30	673	12.38	701	13.55
11888	3200	427	5.18	483	6.60	528	7.92	565	9.06	599	10.21	631	11.40	660	12.53	688	13.70	716	14.96
12631	3400	447	6.05	501	7.54	546	8.99	583	10.25	616	11.45	648	12.73	677	13.96	704	15.16	731	16.45
13374	3600	466	6.97	519	8.57	563	10.10	601	11.54	634	12.85	664	14.10	693	15.42	721	16.77	747	18.09
14117	3800	486	8.01	537	9.68	581	11.35	619	12.91	652	14.34	682	15.70	710	17.04	737	18.42	763	19.83
14860	4000	506	9.15	555	10.89	599	12.69	637	14.39	670	15.94	700	17.41	727	18.77	754	20.25	779	21.67
15603	4200	527	10.44	574	12.26	616	14.06	654	15.90	688	17.64	717	19.15	745	20.70	771	22.19	796	23.70
16346	4400	547	11.78	593	13.73	634	15.61	672	17.58	706	19.46	735	21.08	763	22.74	788	24.25	813	25.86
17089	4600	568	13.30	612	15.32	652	17.26	689	19.28	723	21.29	753	23.13	781	24.91	806	26.52	830	28.14
17832	4800	589	14.93	631	17.01	671	19.10	707	21.18	741	23.33	771	25.30	799	27.20	824	28.92	848	30.64
CFM	OV	5" SP		5.5" SP		6" SP		6.5" SP		7" SP		7.5" SP		8" SP		8.5" SP		9" SP	
		RPM	BHP	RPM	BHP	RPM	BHP	RPM	BHP	RPM	BHP	RPM	BHP	RPM	BHP	RPM	BHP	RPM	BHP
5944	1600	660	7.48																
6687	1800	664	8.25	695	9.17	724	10.06												
7430	2000	671	9.12	700	10.05	729	11.03	756	11.98	783	12.97	809	13.97						
8173	2200	680	10.08	709	11.09	736	12.07	762	13.06	788	14.10	814	15.19	838	16.22	863	17.35	886	18.40
8916	2400	691	11.15	718	12.15	745	13.22	771	14.29	796	15.37	820	16.43	844	17.55	868	18.72	891	19.86
9659	2600	702	12.25	729	13.34	755	14.45	780	15.55	805	16.71	829	17.86	852	19.00	875	20.19	898	21.43
10402	2800	714	13.42	741	14.62	766	15.76	791	16.95	815	18.14	839	19.38	862	20.61	884	21.81	906	23.07
11145	3000	728	14.76	753	15.92	778	17.15	802	18.38	826	19.67	849	20.93	872	22.25	894	23.54	915	24.80
11888	3200	742	16.18	767	17.42	791	18.66	815	19.98	838	21.29	861	22.66	883	23.99	904	25.30	926	26.73
12631	3400	756	17.69	781	19.00	805	20.32	828	21.64	851	23.04	873	24.42	895	25.85	916	27.25	937	28.70
13374	3600	771	19.34	796	20.75	819	22.07	842	23.47	864	24.86	886	26.32	907	27.75	928	29.24	948	30.69
14117	3800	787	21.17	811	22.59	834	24.00	857	25.48	879	26.95	900	28.39	921	29.91	941	31.39	961	32.92
14860	4000	804	23.18	827	24.61	850	26.12	872	27.60	893	29.06	914	30.57	935	32.16	955	33.72	975	35.34
15603	4200	820	25.22	843	26.74	865	28.24	887	29.82	908	31.36	929	32.97	949	34.53	969	36.16	988	37.74
16346	4400	837	27.47	860	29.08	882	30.67	903	32.24	924	33.88	944	35.47	964	37.12	984	38.84	1003	40.49
17089	4600	854	29.85	877	31.55	898	33.12	919	34.78	940	36.51	960	38.19	979	39.82	999	41.63	1017	43.25
17832	4800	871	32.35	893	34.04	915	35.81	936	37.56	956	39.26	976	41.04	995	42.75	1014	44.53	1033	46.37
18575	5000	889	35.10	911	36.89	932	38.64	953	40.48	973	42.27	993	44.14	1012	45.95	1030	47.69	1048	49.48
19318	5200	906	37.87	928	39.76	949	41.61	970	43.55	990	45.43	1009	47.26	1028	49.15	1047	51.12	1065	53.01
20061	5400	924	40.90	946	42.91	967	44.86	987	46.76	1007	48.74	1026	50.65	1045	52.64	1063	54.56	1081	56.53
20804	5600	942	44.09	964	46.20	984	48.12	1004	50.12	1024	52.20	1043	54.21	1062	56.29	1080	58.29	1097	60.20
21547	5800	960	47.42	982	49.65	1002	51.68	1022	53.78	1041	55.81	1060	57.92	1078	59.93	1097	62.19	1114	64.19
CFM	OV	10" SP		11" SP		12" SP		13" SP		14" SP		15" SP		16" SP		17" SP		18" SP	
		RPM	BHP	RPM	BHP	RPM	BHP	RPM	BHP	RPM	BHP	RPM	BHP	RPM	BHP	RPM	BHP	RPM	BHP
9659	2600	941	23.83	984	26.39	1025	28.96	1065	31.58										
10402	2800	948	25.56	990	28.23	1030	30.90	1069	33.63	1107	36.41	1144	39.22						
11145	3000	957	27.47	997	30.14	1036	32.89	1074	35.70	1111	38.57	1148	41.58	1183	44.50	1218	47.55		
11888	3200	967	29.49	1006	32.24	1044	35.07	1082	38.06	1118	41.00	1153	43.97	1188	47.08	1222	50.21	1255	53.34
12631	3400	977	31.54	1016	34.47	1054	37.47	1090	40.43	1126	43.55	1160	46.58	1194	49.74	1228	53.05	1260	56.24
13374	3600	988	33.73	1027	36.85	1064	39.92	1100	43.05	1135	46.22	1169	49.43	1202	52.65	1235	56.01	1267	59.37
14117	3800	1000	36.05	1038	39.26	1074	42.41	1110	45.71	1144	48.93	1178	52.31	1211	55.70	1243	59.10		
14860	4000	1013	38.53	1050	41.82	1086	45.16	1121	48.54	1155	51.94	1188	55.36	1220	58.79	1252	62.36		
15603	4200	1026	41.09	1063	44.55	1098	47.96	1132	51.40	1166	55.00	1199	58.60	1231	62.21	1262	65.81		
16346	4400	1040	43.87	1076	47.37	1111	50.94	1145	54.57	1177	58.08	1210	61.89	1241	65.53				
17089	4600	1054	46.78	1090	50.43	1124	54.02	1157	57.68	1190	61.51	1222	65.36	1253	69.20				
17832	4800	1069	49.95	1104	53.61	1138	57.36	1171	61.17	1203	65.02	1234	68.89	1265	72.92				
18575	5000	1084	53.25	1118	56.93	1152	60.82	1185	64.79	1216	68.63	1247	72.67						
19318	5200	1100	56.81	1133	60.52	1167	64.60	1199	68.54	1230	72.54	1261	76.73						
20061	5400	1116	60.52	1149	64.41	1182	68.51</												

Performance Data

RBF 50

Outlet Area = 4.639 Sq. Ft.

Wheel Dia. = 50.5

Tip Speed = 13.221 x RPM

CFM	OV	0.5" SP		1" SP		1.5" SP		2" SP		2.5" SP		3" SP		3.5" SP		4" SP		4.5" SP			
		RPM	BHP	RPM	BHP	RPM	BHP	RPM	BHP	RPM	BHP	RPM	BHP	RPM	BHP	RPM	BHP	RPM	BHP	RPM	BHP
4639	1000	209	0.63	272	1.14	325	1.71														
5567	1200	222	0.83	282	1.42	333	2.07	377	2.74	418	3.47										
6495	1400	237	1.10	294	1.74	342	2.46	385	3.22	424	4.01	460	4.82	494	5.67						
7422	1600	252	1.41	307	2.13	353	2.91	394	3.74	432	4.61	466	5.46	499	6.39	531	7.37	561	8.35		
8350	1800	268	1.79	322	2.62	366	3.45	405	4.33	441	5.26	475	6.22	507	7.22	537	8.23	566	9.27		
9278	2000	284	2.24	336	3.14	379	4.06	417	5.00	452	6.00	485	7.05	516	8.12	545	9.18	573	10.29		
10206	2200	300	2.74	352	3.79	393	4.76	430	5.77	464	6.83	496	7.94	526	9.09	554	10.22	582	11.43		
11134	2400	315	3.28	368	4.52	408	5.57	444	6.66	477	7.78	508	8.94	537	10.14	565	11.39	591	12.61		
12061	2600	331	3.93	384	5.33	423	6.46	459	7.67	491	8.86	521	10.07	549	11.30	576	12.60	602	13.93		
12989	2800	348	4.69	399	6.17	439	7.49	474	8.77	505	10.02	534	11.29	562	12.62	588	13.94	614	15.38		
13917	3000	364	5.50	415	7.15	455	8.62	489	9.97	520	11.33	548	12.65	575	14.03	601	15.46	626	16.92		
14845	3200	381	6.45	431	8.22	471	9.85	504	11.28	535	12.76	563	14.19	589	15.61	615	17.15	639	18.64		
15773	3400	398	7.49	446	9.33	487	11.18	520	12.75	550	14.29	578	15.84	604	17.37	629	18.95	652	20.45		
16700	3600	416	8.69	462	10.60	503	12.63	536	14.34	566	16.02	593	17.61	619	19.25	643	20.85	666	22.47		
17628	3800	433	9.94	479	12.05	518	14.10	552	16.05	582	17.88	608	19.50	634	21.27	658	22.98	681	24.71		
18556	4000	451	11.37	495	13.55	534	15.76	568	17.89	598	19.86	624	21.62	649	23.41	673	25.24	696	27.09		
19484	4200	469	12.91	512	15.26	550	17.55	584	19.85	614	21.98	640	23.87	665	25.80	688	27.64	710	29.48		
20412	4400	488	14.68	528	17.00	566	19.47	599	21.82	629	24.12	656	26.27	681	28.35	703	30.18	726	32.27		
21339	4600	506	16.49	545	18.97	582	21.52	615	24.04	645	26.51	672	28.82	696	30.91	719	33.00	741	35.09		
22267	4800	525	18.55	562	21.08	598	23.71	631	26.40	661	29.04	688	31.51	712	33.74	735	35.98	757	38.21		
CFM	OV	5" SP		5.5" SP		6" SP		6.5" SP		7" SP		7.5" SP		8" SP		8.5" SP		9" SP			
		RPM	BHP	RPM	BHP	RPM	BHP	RPM	BHP	RPM	BHP	RPM	BHP	RPM	BHP	RPM	BHP	RPM	BHP	RPM	BHP
7422	1600	590	9.35																		
8350	1800	594	10.35	621	11.46	647	12.57														
9278	2000	600	11.43	626	12.59	651	13.76	675	14.93	699	16.17	723	17.47								
10206	2200	608	12.62	633	13.83	657	15.04	681	16.33	704	17.61	727	18.96	749	20.29	771	21.67	792	23.03		
11134	2400	617	13.91	641	15.15	665	16.47	688	17.80	711	19.19	733	20.57	754	21.92	775	23.34	796	24.81		
12061	2600	627	15.29	651	16.65	674	18.01	697	19.44	719	20.86	740	22.26	761	23.72	782	25.25	802	26.75		
12989	2800	638	16.78	661	18.18	684	19.66	706	21.12	728	22.65	749	24.16	769	25.64	789	27.18	809	28.78		
13917	3000	650	18.41	673	19.92	695	21.43	717	23.02	738	24.58	758	26.10	779	27.79	798	29.33	817	30.93		
14845	3200	662	20.13	685	21.74	706	23.26	728	24.96	748	26.54	768	28.18	788	29.88	808	31.65	827	33.36		
15773	3400	675	22.06	697	23.67	719	25.38	740	27.08	760	28.76	780	30.52	799	32.23	818	34.01	836	35.72		
16700	3600	689	24.20	710	25.81	731	27.50	752	29.30	772	31.08	791	32.82	810	34.64	829	36.53	847	38.36		
17628	3800	703	26.45	724	28.17	745	29.99	765	31.77	784	33.51	803	35.34	822	37.26	840	39.13	858	41.06		
18556	4000	717	28.82	738	30.66	758	32.46	778	34.36	797	36.20	816	38.13	835	40.15	853	42.11	870	44.00		
19484	4200	732	31.45	753	33.40	772	35.19	792	37.20	811	39.16	829	41.06	847	43.03	865	45.08	882	47.06		
20412	4400	747	34.23	767	36.16	787	38.19	806	40.18	825	42.26	843	44.27	861	46.36	878	48.35	895	50.42		
21339	4600	762	37.16	782	39.20	802	41.36	821	43.46	839	45.50	857	47.62	874	49.65	891	51.76	908	53.94		
22267	4800	777	40.25	797	42.41	817	44.68	835	46.74	854	49.05	871	51.12	888	53.26	905	55.49	922	57.79		
23195	5000	793	43.67	813	45.96	832	48.18	850	50.34	868	52.60	886	54.96	903	57.22	919	59.37	936	61.79		
24123	5200	809	47.26	828	49.51	847	51.85	865	54.12	883	56.50	901	58.98	918	61.35	934	63.61	950	65.95		
25051	5400	825	51.04	844	53.41	862	55.70	881	58.29	898	60.58	916	63.18	932	65.46	949	68.04	965	70.49		
25978	5600	841	54.99	860	57.50	878	59.92	896	62.44	913	64.85	931	67.57	947	69.96	964	72.66	979	75.00		
26906	5800	857	59.14	876	61.79	894	64.34	912	66.99	929	69.53	946	72.16	962	74.65	979	77.48	994	79.92		
CFM	OV	10" SP		11" SP		12" SP		13" SP		14" SP		15" SP		16" SP		17" SP		18" SP			
		RPM	BHP	RPM	BHP	RPM	BHP	RPM	BHP	RPM	BHP	RPM	BHP	RPM	BHP	RPM	BHP	RPM	BHP	RPM	BHP
12061	2600	841	29.80	879	32.96	916	36.21	951	39.39												
12989	2800	847	31.94	884	35.21	920	38.57	955	42.00	989	45.48	1022	48.98								
13917	3000	855	34.32	891	37.69	926	41.15	960	44.67	993	48.24	1025	51.84	1057	55.61	1088	59.36				
14845	3200	863	36.72	899	40.32	933	43.86	966	47.46	999	51.25	1030	54.92	1061	58.76	1092	62.77	1122	66.77		
15773	3400	873	39.44	907	42.97	941	46.73	974	50.55	1006	54.41	1037	58.30	1067	62.20	1097	66.26	1126	70.32		
16700	3600	882	42.05	917	45.96	950	49.79	982	53.67	1013	57.58	1044	61.69	1074	65.80	1103	69.91	1131	73.99		
17628	3800	893	44.99	927	49.01	959	52.90	991	57.00	1022	61.13	1052	65.28	1081	69.42	1110	73.75				
18556	4000	904	47.99	937	52.08	970	56.39	1001	60.57	1031	64.73	1061	69.10	1090	73.46	1118	77.80				
19484	4200	916	51.25	949	55.56	980	59.76	1011	64.17	1041	68.59	1070	72.98	1099	77.56	1127	82.12				
20412	4400	929	54.81	961	59.15	992	63.56	1022	68.01	1051	72.47	1080	77.12	1108	81.73						
21339	4600	941	58.34	973	62.86	1004	67.48	1033	71.94	1062	76.62	1091	81.52	1119	86.38						
22267	4800	954	62.22	986	66.93	1016	71.53	1045	76.19	1074	81.09	1102	85.99	1129	90.85						

Performance Data

RBF 57

Outlet Area = 5.988 Sq. Ft.

Wheel Dia. = 57.5

Tip Speed = 15.053 x RPM

CFM	OV	0.5" SP		1" SP		1.5" SP		2" SP		2.5" SP		3" SP		3.5" SP		4" SP		4.5" SP			
		RPM	BHP	RPM	BHP	RPM	BHP	RPM	BHP	RPM	BHP	RPM	BHP	RPM	BHP	RPM	BHP	RPM	BHP	RPM	BHP
5988	1000	183	0.81	239	1.48	286	2.23														
7186	1200	195	1.08	248	1.84	292	2.66	331	3.54	367	4.48										
8383	1400	208	1.42	258	2.25	300	3.17	338	4.15	372	5.16	404	6.23	434	7.33						
9581	1600	221	1.82	269	2.74	310	3.76	346	4.83	379	5.94	409	7.05	438	8.24	466	9.50	492	10.74		
10778	1800	235	2.31	282	3.36	321	4.45	355	5.57	387	6.78	417	8.04	445	9.32	471	10.59	497	11.98		
11976	2000	249	2.88	295	4.06	332	5.21	366	6.46	397	7.76	425	9.06	453	10.48	478	11.82	503	13.29		
13174	2200	263	3.53	308	4.85	345	6.14	377	7.43	407	8.80	435	10.23	461	11.68	486	13.17	510	14.68		
14371	2400	276	4.22	322	5.78	358	7.18	389	8.55	418	9.99	446	11.55	471	13.06	495	14.62	519	16.30		
15569	2600	290	5.05	336	6.81	371	8.32	402	9.84	430	11.36	457	12.98	482	14.61	505	16.21	528	17.95		
16766	2800	305	6.03	350	7.96	385	9.65	415	11.24	443	12.91	468	14.51	493	16.27	516	17.99	538	19.76		
17964	3000	319	7.08	364	9.22	399	11.10	428	12.77	456	14.59	481	16.34	504	18.04	527	19.90	549	21.79		
19162	3200	334	8.30	377	10.51	413	12.68	442	14.53	469	16.41	494	18.30	517	20.15	539	22.04	560	23.95		
20359	3400	349	9.65	391	12.01	427	14.40	456	16.42	482	18.37	507	20.41	529	22.28	551	24.32	572	26.37		
21557	3600	364	11.13	405	13.64	440	16.14	470	18.47	496	20.59	520	22.67	542	24.68	564	26.87	584	28.93		
22754	3800	379	12.74	419	15.41	454	18.13	484	20.67	510	22.97	533	25.08	556	27.39	577	29.58	597	31.79		
23952	4000	395	14.60	434	17.45	468	20.27	498	23.03	524	25.52	547	27.81	569	30.13	590	32.47	610	34.82		
25150	4200	411	16.62	448	19.53	481	22.43	511	25.40	538	28.25	561	30.71	582	33.03	603	35.53	623	38.03		
26347	4400	427	18.80	463	21.91	495	24.88	525	28.07	551	30.97	575	33.79	596	36.29	617	38.96	636	41.43		
27545	4600	443	21.16	477	24.31	510	27.67	539	30.92	565	34.04	589	37.06	610	39.74	630	42.40	649	45.02		
28742	4800	459	23.71	492	27.03	524	30.48	553	33.95	579	37.28	603	40.52	624	43.38	644	46.23	663	49.02		
CFM	OV	5" SP		5.5" SP		6" SP		6.5" SP		7" SP		7.5" SP		8" SP		8.5" SP		9" SP			
		RPM	BHP	RPM	BHP	RPM	BHP	RPM	BHP	RPM	BHP	RPM	BHP	RPM	BHP	RPM	BHP	RPM	BHP	RPM	BHP
10778	1800	521	13.33	545	14.78	568	16.23														
11976	2000	526	14.69	549	16.20	571	17.72	593	19.32	614	20.91	635	22.57								
13174	2200	533	16.23	556	17.89	577	19.45	598	21.10	618	22.73	638	24.45	658	26.24	677	27.99	695	29.69		
14371	2400	541	17.89	563	19.60	584	21.30	604	22.98	624	24.75	643	26.49	662	28.31	681	30.22	699	32.06		
15569	2600	550	19.70	571	21.45	592	23.29	612	25.12	631	26.91	650	28.79	668	30.63	686	32.54	704	34.52		
16766	2800	560	21.66	580	23.45	600	25.33	620	27.31	639	29.24	657	31.12	675	33.09	693	35.14	710	37.13		
17964	3000	570	23.71	590	25.63	610	27.67	629	29.67	647	31.62	665	33.64	683	35.75	701	37.95	717	39.91		
19162	3200	581	25.99	601	28.04	620	30.08	638	32.08	657	34.33	674	36.36	692	38.64	709	40.82	725	42.91		
20359	3400	592	28.41	612	30.59	630	32.59	649	34.88	666	36.95	684	39.29	701	41.56	718	43.91	734	46.15		
21557	3600	604	31.12	623	33.29	641	35.41	659	37.65	677	40.02	694	42.32	711	44.73	727	47.04	743	49.44		
22754	3800	616	33.97	635	36.29	653	38.55	671	40.93	688	43.24	705	45.67	721	48.01	737	50.46	753	53.00		
23952	4000	629	37.15	647	39.44	665	41.85	682	44.19	699	46.63	716	49.18	732	51.64	748	54.21	763	56.67		
25150	4200	642	40.51	660	42.95	677	45.31	694	47.79	711	50.38	727	52.87	743	55.45	759	58.14	774	60.72		
26347	4400	655	44.06	673	46.64	690	49.15	707	51.78	723	54.31	739	56.94	755	59.67	770	62.27	785	64.96		
27545	4600	668	47.81	686	50.54	703	53.19	719	55.74	736	58.65	751	61.19	767	64.08	782	66.82	797	69.65		
28742	4800	681	51.75	699	54.63	716	57.43	732	60.12	748	62.94	764	65.87	779	68.66	794	71.55	808	74.26		
29940	5000	695	56.14	712	58.94	729	61.89	745	64.72	761	67.69	777	70.78	792	73.71	806	76.47	821	79.61		
31138	5200	709	60.76	726	63.73	742	66.57	758	69.55	774	72.66	789	75.62	804	78.70	819	81.89	833	84.89		
32335	5400	723	65.60	739	68.47	756	71.75	772	74.89	787	77.86	803	81.27	817	84.19	832	87.54	846	90.69		
33533	5600	737	70.69	753	73.72	770	77.18	785	80.18	801	83.62	816	86.88	830	89.94	845	93.44	859	96.73		
34730	5800	751	76.01	767	79.21	783	82.55	799	86.03	814	89.31	829	92.73	843	95.93	858	99.59	872	103.03		
35928	6000	765	81.57	781	84.95	797	88.47	813	92.13	828	95.59	843	99.17	857	102.53	871	106.00	885	109.59		
CFM	OV	10" SP		11" SP		12" SP		13" SP		14" SP		15" SP		16" SP		17" SP		18" SP			
		RPM	BHP	RPM	BHP	RPM	BHP	RPM	BHP	RPM	BHP	RPM	BHP	RPM	BHP	RPM	BHP	RPM	BHP		
15569	2600	738	38.43	772	42.61	804	46.71	835	50.87												
16766	2800	744	41.31	776	45.45	808	49.86	838	54.15	868	58.66	897	63.18								
17964	3000	750	44.21	782	48.63	813	53.14	843	57.72	872	62.34	900	66.96	928	71.80	956	76.83				
19162	3200	758	47.50	789	52.02	819	56.62	848	61.27	877	66.17	904	70.85	932	76.00	959	81.13	985	86.19		
20359	3400	766	50.85	796	55.44	826	60.32	855	65.25	883	70.22	910	75.18	937	80.38	963	85.54	988	90.64		
21557	3600	774	54.25	805	59.35	834	64.30	862	69.28	890	74.53	916	79.52	942	84.74	968	90.18	993	95.56		
22754	3800	784	58.12	813	63.11	842	68.35	870	73.61	897	78.88	923	84.14	949	89.64	974	95.09	999	100.76		
23952	4000	793	61.85	822	67.13	851	72.70	878	78.01	905	83.57	931	89.10	957	94.89	981	100.32				
25150	4200	804	66.17	832	71.48	860	77.10	887	82.73	914	88.62	939	94.15	964	99.91	989	105.92				
26347	4400	814	70.39	843	76.22	870	81.86	897	87.79	923	93.71	948	99.57	973	105.64	997	111.61				
27545	4600	825	75.06	853	80.87	880	86.75	907	92.97	932	98.88	957	105.04	981	111.11						
28742	4800	837	80.23	864	85.98	891	92.12	917	98.29	942	104.47	967	110.92	991	117.30						
29940	5000	848	85.30	876	91.63	902	97.69	928	104.12	953	110.55	977	116.94								
31138	5200	861	91.17	887	97.18	913	103.50	939	110.17	963	116.49	987	123.12								
32335	5400	873	96.95	899	103.24	925	109.86	950	116.45	974	122.99	998	129.88								
33533	5600	886	103.29	912	109.88	937	116.45	961	122.95	986	130.15										
34730	5800	898	109.52	924	116.39	949	123.25	973	130.05	997	137.15										
35928	6000	911	116.36	937	123.54	962	130.70	986	137.79												
37126	6200	924	123.46	950	130.95	974	137.99	998	145.37												
38323	6400	937	130.85	963	138.63	987															

Dimensional Data – Arrangement 1 & 9

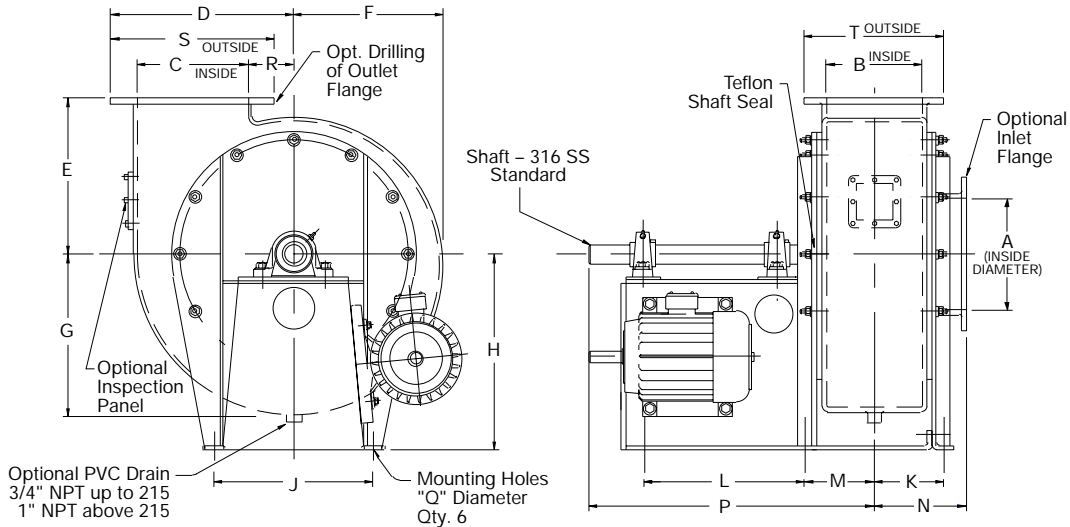

SIZE	A	B	C	D	E	F	G	H	J	K	L	M
15	9	7 ³ / ₄	8 ⁷ / ₈	14 ⁹ / ₁₆	11 ¹³ / ₁₆	10 ¹⁵ / ₁₆	12	18 ³ / ₄	16 ¹ / ₂	5 ⁷ / ₁₆	15	6 ⁷ / ₁₆
19	11	9 ¹ / ₈	10 ⁹ / ₈	17 ¹ / ₁₆	14 ¹ / ₈	13 ¹ / ₂	14 ¹ / ₂	21 ³ / ₄	18 ⁷ / ₈	6 ¹ / ₈	20	7 ¹ / ₈
22	13	10 ³ / ₄	12 ² / ₁₆	20 ¹ / ₈	16 ¹ / ₄	15 ³ / ₄	17	22 ¹ / ₄	22 ¹ / ₄	6 ¹⁵ / ₁₆	20	7 ¹⁵ / ₁₆
26	15	12 ¹ / ₂	14 ⁷ / ₁₆	22 ¹⁹ / ₁₆	18 ³ / ₈	18 ¹ / ₄	19 ¹¹ / ₁₆	24 ¹ / ₄	25 ³ / ₄	7 ⁷ / ₈	22 ¹ / ₄	8 ⁷ / ₈
29	17	14 ¹ / ₈	16 ⁵ / ₁₆	25 ⁷ / ₈	20 ⁷ / ₁₆	20 ⁵ / ₈	22 ⁷ / ₁₆	27	29	8 ¹⁵ / ₁₆	21 ³ / ₄	9 ¹⁵ / ₁₆
33	19	15 ³ / ₄	18 ¹ / ₈	29 ¹ / ₈	22 ¹ / ₂	21 ⁵ / ₈	24 ⁷ / ₈	30 ¹ / ₂	32 ¹ / ₂	9 ³ / ₄	24 ¹ / ₂	10 ³ / ₄
36	21	17 ⁷ / ₁₆	20 ¹ / ₁₆	31 ¹⁵ / ₁₆	24 ⁵ / ₈	25 ¹ / ₁₆	27 ⁷ / ₁₆	33 ¹ / ₂	35 ¹ / ₄	10 ²³ / ₃₂	24 ¹ / ₂	11 ²³ / ₃₂
40	23	19 ¹ / ₈	21 ¹⁵ / ₁₆	34 ³ / ₄	26 ¹³ / ₁₆	26 ¹⁵ / ₁₆	30	36	39	11 ⁹ / ₁₆	26 ¹ / ₄	12 ⁹ / ₁₆
45	26	21 ¹ / ₁₆	24 ¹³ / ₁₆	39	29 ⁷ / ₈	29 ¹³ / ₁₆	33 ³ / ₈	40 ³ / ₄	46 ¹ / ₄	13 ¹³ / ₃₂	25 ¹ / ₄	14 ¹³ / ₃₂
50	29	24 ¹ / ₈	27 ¹¹ / ₁₆	43 ³ / ₈	33 ³ / ₈	32 ¹¹ / ₁₆	38	45	47 ¹ / ₂	14 ¹¹ / ₁₆	30 ³ / ₄	15 ¹¹ / ₁₆
57	33	27 ³ / ₈	31 ¹ / ₂	49 ¹ / ₁₆	37 ³ / ₈	36 ¹ / ₂	39 ¹ / ₈	50 ³ / ₄	53 ¹ / ₂	16 ⁵ / ₁₆	30 ³ / ₄	17 ⁵ / ₁₆
SIZE	N	P	Q	R	S	T	U	V	W	X	MAX. MTR.	SHAFT
15	8 ¹⁵ / ₁₆	27	9 ¹ / ₁₆	3 ¹⁵ / ₁₆	12 ³ / ₈	11 ¹ / ₄	11 ¹⁵ / ₃₂	18 ²¹ / ₃₂	12 ¹⁷ / ₃₂	10 ³ / ₈	215T	1 ⁷ / ₁₆
19	9 ⁵ / ₈	33 ³ / ₁₆	9 ¹ / ₁₆	4 ¹⁵ / ₁₆	14 ¹ / ₈	12 ³ / ₈	14	22 ⁷ / ₃₂	15 ⁵ / ₃₂	12 ¹¹ / ₁₆	256T	1 ¹¹ / ₁₆
22	10 ⁵ / ₁₆	34	9 ¹ / ₁₆	5 ¹³ / ₁₆	16 ¹ / ₄	14 ¹ / ₄	16 ³ / ₈	25 ²³ / ₃₂	17 ¹³ / ₁₆	14 ⁷ / ₈	256T	1 ¹¹ / ₁₆
26	10 ¹⁵ / ₁₆	38	9 ¹ / ₁₆	6 ³ / ₄	17 ¹⁵ / ₁₆	16	18 ³¹ / ₃₂	29 ⁷ / ₃₂	20 ⁹ / ₁₆	17 ³ / ₁₆	284T	1 ¹⁵ / ₁₆
29	11 ¹¹ / ₁₆	38 ¹³ / ₁₆	9 ¹ / ₁₆	7 ¹³ / ₁₆	19 ¹³ / ₁₆	17 ⁵ / ₈	21 ¹⁵ / ₃₂	32 ³ / ₄	23 ¹¹ / ₃₂	19 ¹³ / ₃₂	286T	1 ¹⁵ / ₁₆
33	13 ⁷ / ₈	43 ¹ / ₈	1 ¹ / ₁₆	8 ³ / ₄	22 ⁵ / ₈	19 ¹ / ₄	23 ²⁹ / ₃₂	36 ¹ / ₂	25 ⁷ / ₈	21 ¹⁹ / ₃₂	324T	2 ³ / ₁₆
36	14 ¹⁷ / ₃₂	44 ³ / ₃₂	1 ¹ / ₁₆	9 ⁵ / ₈	24 ⁹ / ₁₆	22 ⁷ / ₁₆	26 ¹¹ / ₃₂	40	28 ⁹ / ₁₆	23 ¹³ / ₁₆	326T	2 ⁷ / ₁₆
40	15 ³ / ₈	47 ⁷ / ₁₆	1 ¹ / ₁₆	10 ⁹ / ₁₆	26 ⁷ / ₁₆	24 ¹ / ₈	28 ⁷ / ₈	43 ¹⁷ / ₃₂	31 ¹ / ₄	26 ⁷ / ₈	365T	2 ⁷ / ₁₆
45	17 ¹ / ₃₂	48 ²⁹ / ₃₂	1 ³ / ₁₆	11 ¹⁵ / ₁₆	29 ⁵ / ₁₆	26 ⁶ / ₁₆	32 ¹⁵ / ₃₂	48 ²³ / ₃₂	35 ⁵ / ₁₆	29 ⁵ / ₁₆	365T	2 ¹¹ / ₁₆
50	17 ⁷ / ₁₆	56 ¹⁵ / ₁₆	1 ³ / ₁₆	13 ⁷ / ₁₆	32 ³ / ₁₆	29 ¹ / ₈	36 ¹³ / ₃₂	54 ³ / ₃₂	39 ⁹ / ₁₆	32 ¹³ / ₁₆	405T	3 ³ / ₁₆
57	18 ⁷ / ₈	58 ⁹ / ₁₆	1 ³ / ₁₆	15 ⁵ / ₁₆	36	32 ³ / ₈	39 ³ / ₁₆	61 ¹ / ₈	42 ³¹ / ₃₂	37 ⁵ / ₃₂	405T	3 ⁷ / ₁₆

NOTE: Arrangement 10 available for sizes 15 through 36. Contact factory for dimensional data.

Dimensions are not to be used for construction.

Fan Discharge Options

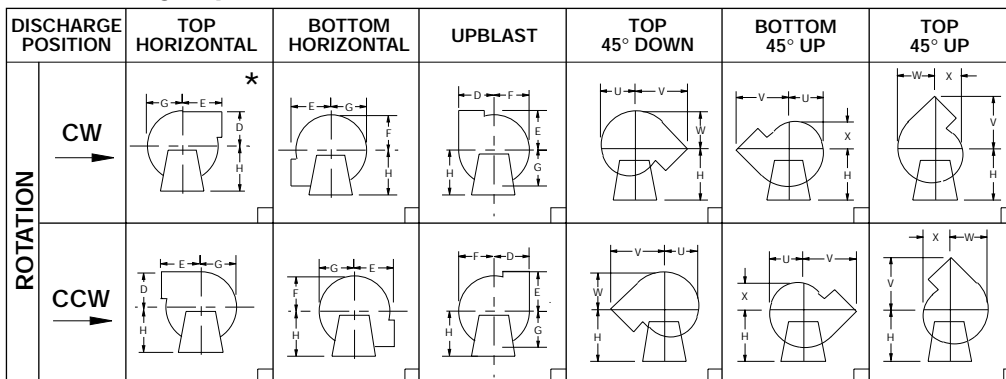

*STANDARD POSITION & ROTATION

Dimensional Data – Arrangement 10

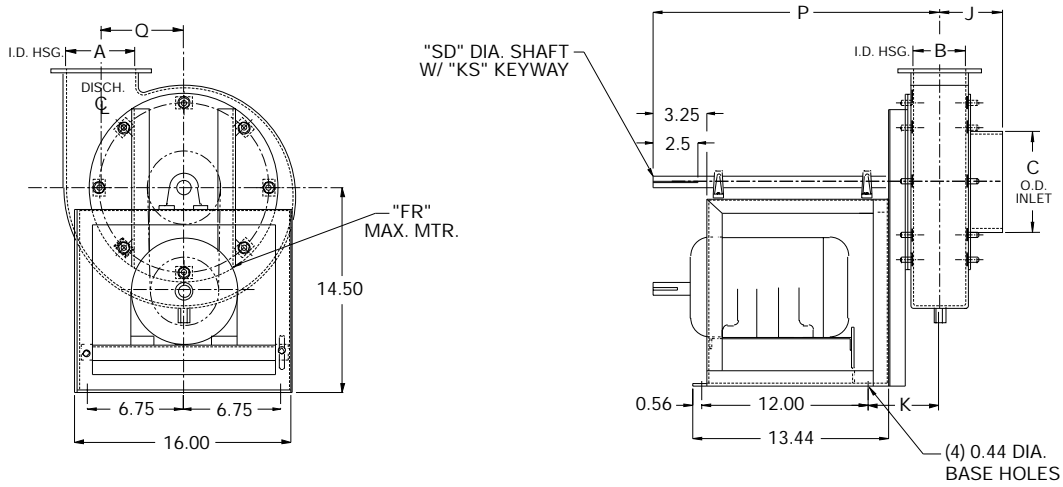

SIZE	A	B	C	FR	HD	HE	HF	HG	HH
10	4	3 ³ / ₈	6 ³ / ₈	56	8 ¹ / ₄	8 ¹ / ₄	8 ¹ / ₄	7 ¹⁵ / ₁₆	7 ⁷ / ₁₆
12	5	3 ⁷ / ₈	7 ³ / ₈	145T	9 ¹ / ₂	9 ¹ / ₄	9 ¹ / ₂	9 ¹ / ₁₆	8 ¹¹ / ₁₆
13	7 ¹ / ₁₆	5 ¹ / ₂	8 ³ / ₈	145T	11 ²⁵ / ₃₂	11 ⁷ / ₈	11 ³ / ₄	11 ⁵ / ₁₆	10 ⁷ / ₁₆
SIZE	HJ	HK	HN	J	K	KS	P	Q	SD
10	8 ³¹ / ₃₂	13 ¹ / ₈	9 ⁹ / ₁₆	4 ¹ / ₁₆	2 ³ / ₄	1/4 x 1/8	19 ¹ / ₁₆	6 ¹ / ₁₆	1
12	10 ⁹ / ₃₂	15 ¹ / ₄	11 ¹ / ₄	4 ⁵ / ₁₆	4 ⁷ / ₈	1/4 x 1/8	19 ⁵ / ₁₆	7 ¹ / ₄	1 ³ / ₁₆
13	11 ²⁷ / ₃₂	17 ³ / ₈	12 ¹¹ / ₁₆	4 ¹³ / ₁₆	5 ¹¹ / ₁₆	1/4 x 1/8	20 ¹ / ₈	7 ⁵ / ₈	1 ³ / ₁₆

Dimensions are not to be used for construction.

Fan Discharge Options

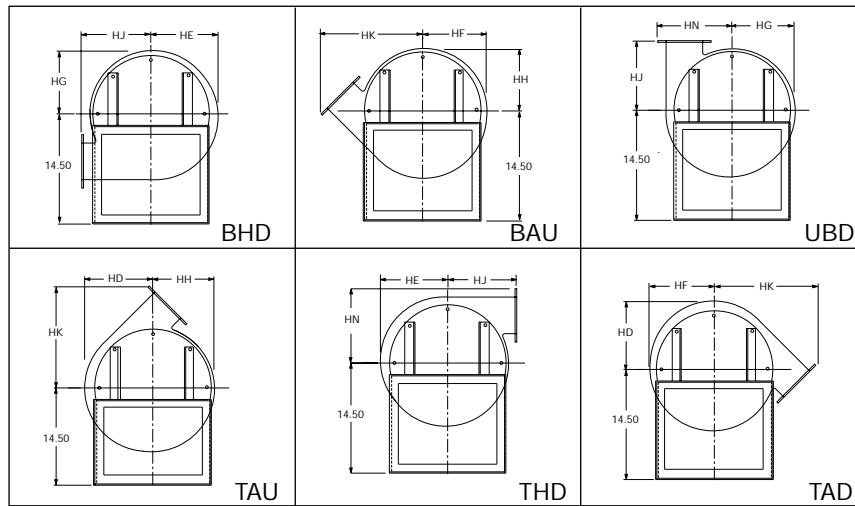

Typical Specifications

Fans shall be of the Radial Blade Fiberglass (Model RBF) Centrifugal type as manufactured by Aerovent, Minneapolis, Minnesota, and shall be of the size and capacity as indicated in the fan schedule. Centrifugal fans shall be tested and rated in accordance with industry accepted test codes, and are guaranteed by the manufacturer to deliver rated performance. In addition, each unit shall be factory run tested prior to shipment.

WHEEL — The type RBF radial wheel shall be constructed using glass cloth impregnated with vinyl ester resin. Wheels shall be statically and dynamically balanced.

HOUSING — The housing shall be of solid hand lay-up corrosion resistant fiberglass reinforced vinyl ester mounted on an all welded, heavy-gauge steel base with Arrangement 1, 9 or 10. Sizes 10, 12 and 13 in Arrangement 10 only. All airstream hardware shall be of FRP encapsulated 316 stainless steel for maximum corrosion resistance.

BEARINGS — Bearings shall be of a regreasable pillow block type and shall have a minimum L-10 life as defined by AFBMA of at least 40,000 hours (200,000 hours average life).

DRIVE — The belts and sheaves furnished by the manufacturer shall be selected to provide additional allowances of 1.3 to 2 times the normal satisfactory capacity.

MOTOR — Fan motors shall be foot mounted NEMA Design B, heavy duty industrial, continuous duty, ball bearing, variable torque type suitable for operation on voltage, phase and hertz, as listed in the fan schedule. Motor bearings shall have a minimum L-10 life as defined by AFBMA of at least 40,000 hours (200,000 hours average life).

BALANCING — The wheel assembly shall be statically and dynamically balanced in accordance with ANSI/AMCA 204-96 "Balance Quality and Vibration Levels for Fans" to Fan Application Category BV-3, Balance Quality Grade G6.3. In addition, belt driven fan propellers shall be balanced on the fan shaft after final assembly in the fan casing, in the manufacturing facility, to the following peak velocity values, filter-in, at the fan test speed:

Fan Application Category	Rigidly Mounted (in./s)	Flexibly Mounted (in./s)
BV-3	0.15	0.20

FINISH — All steel parts are finished with light gray epoxy enamel paint. All fiberglass parts are coated inside and outside with resin (with UV inhibitor), approximately 10 mils in thickness, to seal the surface and provide a smooth, shiny finish. Optional resins and finishes include:

- Synthetic Surface Veil Fire-Retardant Resin

SOUND POWER LEVELS — The sound power level of the fan(s) shall not exceed:

Octave Band-CPS (Sound Power 10⁻¹²)

63	125	250	500	1000	2000	4000	8000

ACCESSORIES — The fan(s) shall be furnished complete with:

- Bolted Cleanout Door
- Weather Cover (Arr. 10, Sizes 10" – 36" only)
- OSHA Type Belt Guard (Arr. 1 & 9, Sizes 15" – 57")
- Shaft & Bearing Guard
- Flanged Inlet (Drilling Standard)
- Unitary Base (Arr. 1)
- Vibration Isolation (RIS/Spring)
- Housing Drain
- Spark Resistant Construction