

Adjustable Pitch Propeller Taper-Lock Hub Reversible Propeller

Assembly Procedures

1. Lay hub on a horizontal surface with openings of shank sockets (Fig. 3) facing up. This is normally the discharge side of the assembly.
2. Lay blade shank in socket with discharge side of the blade up. The discharge side of the blade is the side with the angle setting mark. Line up the index mark on the blade with the proper angle mark on the end of the shank socket (Figs. 2 and 4) on the underside of assembly.
3. Place cap over blade shank with beveled end toward center. Install U-bolts and elastic nut stops. Before tightening lock nuts, pull the blade outward to set the key against the keyway and check angle setting (Fig. 3).
4. Tighten elastic stop nuts evenly and torque to the following foot-pounds:

PROPELLER DIA.	HUB DIA.	U-BOLT SIZE	TORQUE (FT/LBS)
54" - 72"	14"	1/2"	20
81" - 96"	18"	3/4"	45

5. Check angle setting to be sure it has not changed during assembly. If so, loosen lock nuts and reset angle. Tighten nuts again to proper torque. Do not over-tighten. Be sure to tighten U-bolts evenly.

Setting Angle With Protractor (optional)

Under most conditions, the preceding assembly procedure using the index marks is of sufficient accuracy. When greater accuracy is desired, use a level bubble protractor. Before the final tightening of the nuts, set the protractor on the angle setting mark. (The hub and blade assembly must be level for accurate setting.) Adjust the angle by tapping the shank end with a mallet. Tighten lock nuts to proper torque. Again check the angle setting. Rotate propeller to check angle on each blade in the same location.

Propellers may be assembled so the cap side of the hub is the inlet side (reverse bore). If blades do not have the index mark on the discharge side, it is then necessary to adjust the blade angle with a protractor.

The hub and blades are balanced separately. The weight distribution throughout the length of the blade varies slightly. Therefore, the balance is to a constant moment and blades may be assembled at random even though the weights are slightly different.

Fig. 1

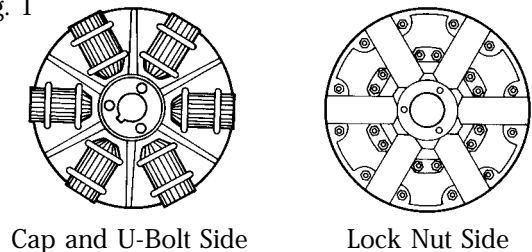
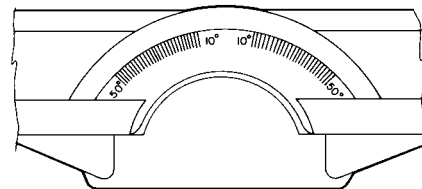

Fig. 2



Angle setting index on shank socket. Marked from 10° through 50°. Each mark is 2°.

Fig. 3

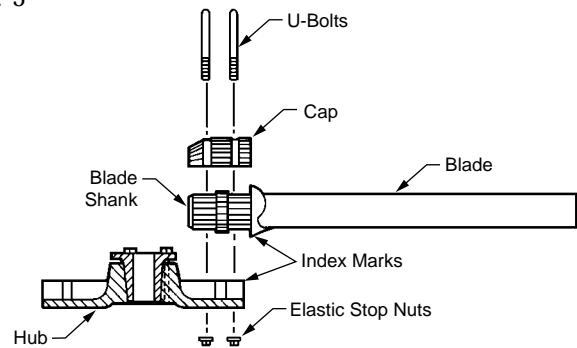
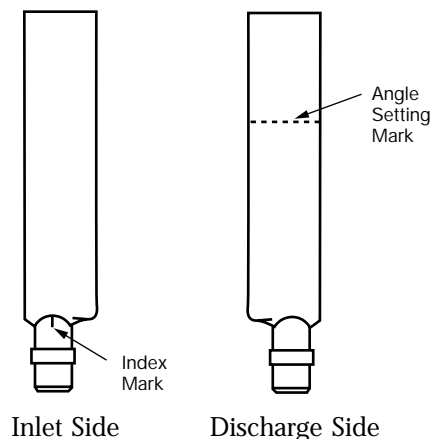

Fig. 4



Installation Instructions For Propellers Equipped With Browning Malleable Iron Split Taper Bushings

Aerovent adjustable pitch propellers are furnished with hubs that have a tapered bore. A split taper bushing is used for mounting the propeller assembly to the shaft. When properly assembled, the bushing grips the hub and the shaft with a positive clamping action. The split taper bushing is always mounted on the discharge or cap side of the hub unless the propeller has been ordered with a reverse bore.

- A. Bushing barrel and bore of propeller hub are tapered. This assures concentric mounting and a true running propeller.
- B. Capscrews, when tightened, lock bushing in propeller. Use plated capscrews threaded full length (see table below).

BUSH NO.	CAPSCREW			TORQUE (FT/LBS)
	SIZE	THREADS/IN	LENGTH	
Q2	3/8"	16	2 1/2"	24
R2	3/8"	16	3"	24
P2	5/16"	18	3 3/4"	13

- C. Bushing is split so that when the locking capscrews force bushing into tapered bore, the bushing grips the shaft with a positive clamping fit. This will withstand vibration and punishing loads without being loosened.
- D. Propeller and bushing assembly is keyed to shaft and held in place by compression. This gives added driving strength.

Installation Instructions

Put bushing loosely into propeller. Do not press or drive. Start capscrews by hand, turning them just enough to engage threads in tapped holes on propeller. Do not use a wrench at this time. The bushing should be loose enough in the propeller to move slightly.

Be sure shaft and keyway are clean and smooth. Check key size with both shaft and bushing keyways. Slide propeller and bushing assembly onto shaft, making allowance for end play of shaft to prevent rubbing. Do not force propeller and bushing onto shaft. If it does not go on easily, check shaft, bushing and key sizes.

Tighten capscrews progressively with wrench. Do this evenly as in mounting an automobile wheel. Take a part turn on each capscrew successively until all are tight.

These capscrews force the taper bushing into the hub which in turn compresses the bushing onto the

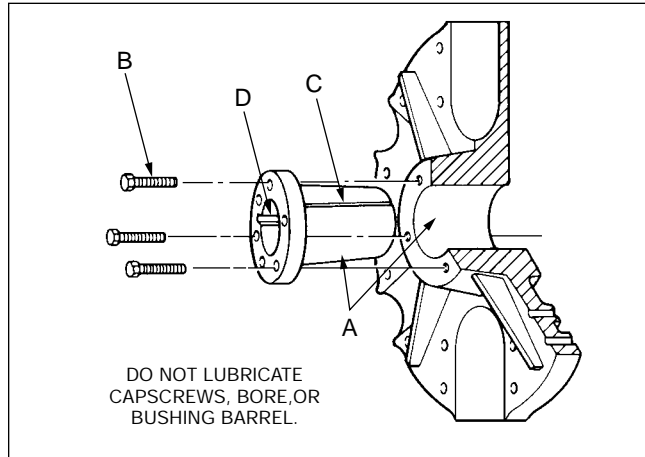

shaft. This makes a positive clamping fit. The torque must not exceed the torque values shown in the chart to the left.

WARNING: Do not attempt to pull bushings flange flush with hub end. There should be 1/8" to 1/4" clearance when tightened.

Checking Bushing Torque

On kiln installations, it is necessary to check the bushing bolt torque after start-up. Torque the bolts after any initial run-in period and after the first 24 hours or first run of lumber through the kiln. Tightening of the bolts while the assembly is still warm from the kiln heat will help to maintain proper torque. Periodic checking of torque on a regular maintenance schedule is recommended.

Removing Propeller Assembly From Shaft

1. Remove all three capscrews from propeller and hub assembly.
2. Start capscrews into the threaded holes in the bushing flange.
3. Tighten each bolt part of a turn successively to force the propeller off the bushing.
4. Pull the bushing off the shaft. If the assembly has been in place some time, it may be necessary to use a wheel puller to remove the bushing. Never use a wheel puller on the propeller.

For propeller dimensions, see drawing B8709B.



A Twin City Fan Company

5959 Trenton Lane · Minneapolis, MN 55442-3238
Phone (612) 551-7500 · Fax (612) 551-7501 · Website www.aerovent.com

