

## Type 'E' Adjustable Pitch Propeller

### Blade Angle Adjustment

Blades are set to the specified blade angle at the factory. If adjustment in the field is required, use one of the following two methods:

#### Preferred Method (more accurate)

1. Lay the hub on a horizontal surface with the concave (air leaving) surfaces of the blades facing upwards.
2. Loosen the blade retaining bolts until they are finger-tight. At this point, the blades should rotate in their sockets when grasped firmly and twisted, but not turn on their own.
3. Place an angle meter across the two blade angle position marks on a blade. See Figure 1.
4. Twist the blade to the desired blade angle.
5. Repeat steps 3 and 4 for the remaining blades.
6. Re-tighten the blade retaining bolts to the torque shown in Table 1. Work in a star pattern, working your way up to the desired torque in steps. Tightening one bolt to the full torque before moving on to the next can crack the hub.

Table 1.

FAN SIZE	HUB DIA.	BUSHING	TORQUE (ft. lbs.)	
			BLADE BOLT	BUSHING BOLT
14 - 24	6"	H	17	7.5
30 - 36	9"	P	30	13
42 - 48	12"	P	75	13
42 - 48	12"	Q	75	24

Figure 1.

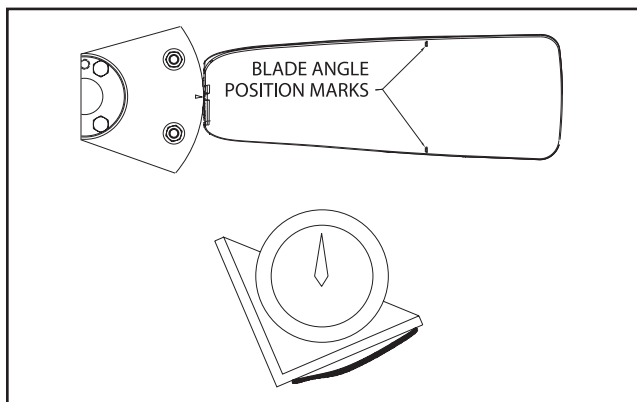

#### Alternate Method

1. Loosen the blade retaining bolts until they are finger-tight. At this point, the blades should rotate in their sockets when grasped firmly and twisted, but not turn on their own.

2. Angle setting marks on the blade line up with an indicating arrow on the hub. There are two long marks on the blade, one for 12° blade angle and another for 32°. Shorter indicating marks at 5° increments are in between the two longer marks. See Figure 2 below.
3. Twist each blade to the desired blade angle.
4. Re-tighten the blade retaining bolts to the torque shown in Table 1. Work in a star pattern, working your way up to the desired torque in steps. Tightening one bolt to the full torque before moving on to the next can crack the hub.

Figure 2.

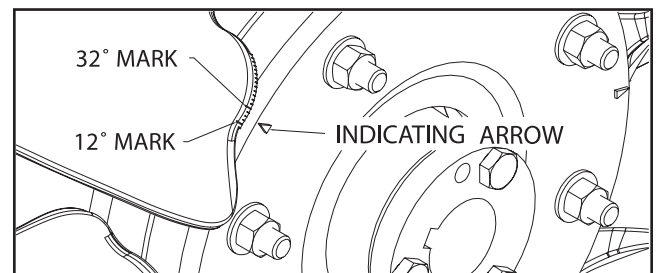

### Mounting the Propeller Assembly on the Shaft

Type 'E' propellers are furnished with hubs that have a tapered bore. A split-tapered bushing is used for mounting the propeller assembly to the shaft. When properly assembled, the bushing grips the hub and the shaft with a positive clamping action. See Figure 3 below.

- A. The bushing barrel and the bore of the propeller hub are tapered. This assures concentric mounting and a true running propeller.

Figure 3.

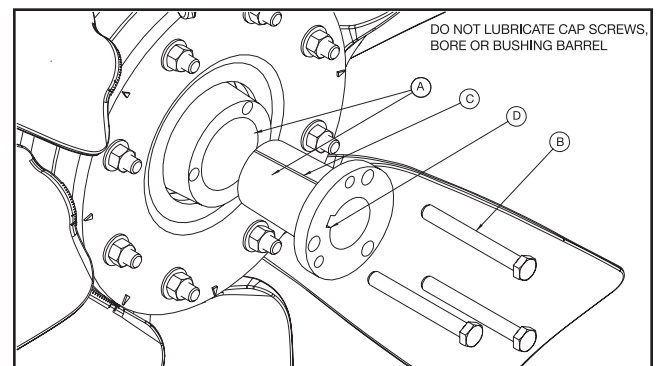

- B. The cap screws, when tightened, lock the bushing in the propeller.
- C. The bushing is split so that when the locking cap screws force the bushing into the tapered bore, the bushing grips the shaft with a positive clamping fit. This will withstand vibration and punishing loads without loosening.
- D. The propeller and bushing assembly is keyed to the shaft and held in place by compression. This gives added driving strength.

Put the bushing loosely into the propeller. Do not press or drive. Start the cap screws by hand, turning them just enough to engage the threads in the tapped holes on the propeller. Do not use a wrench at this time. The bushing should be loose enough in the propeller to move slightly. Be sure the shaft and keyway are clean and smooth. Check the key size with both the shaft and bushing keyways. Slide the propeller and bushing assembly onto the shaft, making allowance for endplay in the shaft to prevent rubbing. Do not force the propeller and bushing onto the shaft. If it does not go on easily, check the shaft, bushing, and key sizes.

Tighten the caps screws progressively with a wrench. Do this evenly as in mounting an automobile wheel. Take a part turn on each cap screw successively until all are tightened to the torque shown in Table 1.

These cap screws force the tapered bushing into the hub, which in turn compresses the bushing on to the shaft.

**WARNING:** Do not attempt to pull the bushing flange flush with the hub end. There should be 1/8" to 1/4" clearance when tightened.

## Removing the Propeller Assembly from the Shaft

The propeller is easily removed from the shaft by inserting and tightening two of the cap screws into the tapped holes in the bushing flange. This forces the bushing loose from the propeller and releases the compression so that the entire assembly will slide off the shaft.

1. Remove all the cap screws from the propeller and hub assembly.
2. Start the cap screws into the threaded holes in the bushing flange.
3. Tighten each bolt part of a turn successively to force the propeller off the bushing.
4. Pull the bushing off the shaft. If the assembly has been in place for some time, it may be necessary to use a wheel puller to remove the bushing. Never use a wheel puller on the propeller.



# Aerovent

*A Twin City Fan Company*

5959 Trenton Lane · Minneapolis, MN 55442-3237

Phone (763) 551-7500 · Fax (763) 551-7501 · [www.aerovent.com](http://www.aerovent.com)

5MPP06/04

