



# ENGINEERING DATA

Aerovent • Twin City Fan & Blower • Clarage

## Plenum Fan Application Guidelines

### Duct Entrance Losses from Plenum Fan Cabinet

To achieve the air velocity in the discharge duct and overcome the loss associated with the air entering the ductwork, additional resistance must be added to the external static pressure (ESP) requirements of the fan. Different types of duct entrances and locations will require varying correction factors. Therefore, prior to selecting a fan, make the following correction, depending upon the type of duct and its location.

ADDITIONAL DUCT ENTRANCE LOSS TO BE ADDED TO FAN ESP	
DISCHARGE TYPE	CORRECTION FACTOR
<ul style="list-style-type: none"> <li>● Radial and ducted with bell-mouth</li> <li>● Radial and ducted without bell-mouth</li> <li>● Radial without duct or bell-mouth</li> <li>● Flow parallel to shaft and ducted with bell-mouth</li> <li>● Flow parallel to shaft and ducted without bell-mouth</li> <li>● Flow parallel to shaft without duct or bell-mouth</li> </ul>	<p>1.1 x Duct Velocity Pressure</p> <p>1.4 x Duct Velocity Pressure</p> <p>1.8 x Duct Velocity Pressure</p> <p>1.6 x Duct Velocity Pressure</p> <p>1.9 x Duct Velocity Pressure</p> <p>2.4 x Duct Velocity Pressure</p>

**Example:** A system requires 30,000 CFM at 5" SP at standard air density with one 4 ft. diameter duct with bell-mouth placed in a radial discharge. Determine RPM and brake horsepower:

$$\text{Duct area} = (4^2 \times \pi) \div 4 = 12.57 \text{ ft}^2$$

$$\text{Duct velocity} = 30,000 \div 12.57 = 2387 \text{ FPM}$$

$$\text{Duct velocity pressure} = (2387 \div 4005)^2 = 0.355 \text{ @ std. cond.}$$

$$\text{Entrance loss correction factor} = 1.1 \times \text{duct velocity pressure} \\ = 1.1 \times 0.355 = 0.39$$

$$\text{Thus, select the fan for} = 5" + 0.39" = 5.39" \text{ S.P.}$$

## Application Guidelines

### Fan Selection Recommendations

1. System effect losses (see AMCA 201) and plenum losses should be estimated and added to the required static pressure, prior to making selections. Refer to AMCA Publication 201 at [www.amca.org](http://www.amca.org) and Twin City Fan Engineering Data Letter "Fan Performance Troubleshooting Guide" (ED-100) at [www.tcf.com](http://www.tcf.com).
2. Fans should be selected so that the point of operation is approximately between 55% and 90% of the free delivery point on the fan curve.
3. Avoid selections over 4000 RPM. A narrow width, larger size impeller can be used to avoid this.
4. Arrangements 1 and 4 will offer the best efficiency and lowest noise as there are no inlet obstructions.
5. Where space is available, mount the fan and motor on a sub-base. The motor can be mounted on the fan on Arrangements 3HS, 3HA, 3SM, 3VS and 3VA.
6. Use inertia-type isolation bases or rigid mounting for lowest fan vibration. Rigid mounting requires dynamic analysis (by others) of the support structure to avoid resonance.
7. Applications exceeding 10" SP are prone to high system effect losses. Use of housed fans (BAE-DWDI) should be considered.
8. Where static pressures over 8" wg are required, Type EPQ or EPQN are preferred because of lower operating speeds and improved stability. Select the fan so the design pressure is at least 10% below the peak pressure.
9. Where flow monitoring is required, use a piezometer ring or externally mounted flow measurement station. Fan performance may be substantially affected by flow measurement probes mounted directly in the fan inlet cone. Refer to page 5 of Bulletin 470 for more information.
10. For direct drive fans without speed control (or where speed control cannot exceed 60 Hz), select fans at 3 – 5% below the nominal speed of the motor. This will normally cover the uncertainties associated with the system and air balancer's measurements. Select motors loaded no closer than 90% of the maximum loading of the motor.

11. For multiple fans in a plenum, alternate CW and CCW rotation fans to minimize losses. If fans are not counter-rotating, install walls between each fan to create cells in the outlet plenum.
12. Add losses for duct take-offs per the chart on page 1 to pressure requirements of the fan. Bell-mouthed entries will always reduce losses and are recommended.
13. For highest reliability, specify the required bearing life. For example, the statement "minimum L-10 bearing life = 100,000 hours" allows for the best bearing to be put on the fan without creating other problems. Some specifications state "use split roller bearings." This can cause a number of problems, such as:
  1. On smaller fans, there may not be enough radial load to prevent roller skidding. This is especially a problem for Arrangement 3 fans.
  2. Split roller bearings are not offered in sizes smaller than  $1\frac{7}{16}$ " bore. Smaller fans use shafts smaller than this.
  3. The oversized bearing in the inlet will block some air in smaller fans (above the losses that are already included in the EPF/EPQ ratings).

### Location and Placement of Fans in Air Handlers

1. Center the fan inlets in both the horizontal and vertical planes.
2. For inlet clearance, see Figure 1. The flow should converge at an angle not greater than  $45^\circ$  when approaching the opening for the fan inlet. A minimum of one fan wheel diameter clearance is recommended.
3. In the fan outlet plenum, a minimum wall clearance of one-half fan wheel diameter to the periphery of the fan wheel is recommended.
4. Figure 1 shows that the minimum clearance between the back of the fan wheel and the nearest component downstream (Dim. E) should be one wheel diameter. Small clearances do not allow the flow to equalize behind the fan wheel and the pressure drop of the downstream component is increased.
5. When the flow enters the inlet plenum perpendicular to the fan shaft, large system effect losses can occur. See Figure 2 for a recommended flow baffle or a vortex breaker that may help preserve rated fan performance.
6. When two or more fans are installed in a plenum, divide the plenum into imaginary cells of equal area. Center the fan inlets on each cell. See Figure 3.

### Installation Recommendations

1. Install the fan so the flexible connector on the inlet remains uncollapsed during operation.
2. Install thrust restraints (snubbers) to maintain the axial position of the fan when it is generating pressure.
3. Peripheral equipment, such as electrical components, inverters, control panels, etc., should be positioned away from the high velocity air entering or leaving the fan.
4. Adjust springs on the isolation base so that spring deflection is approximately equal for all isolators.
5. Follow safety, installation, start-up, and maintenance instructions supplied with each fan.

Figure 1. Recommended Location of Fan in Plenum

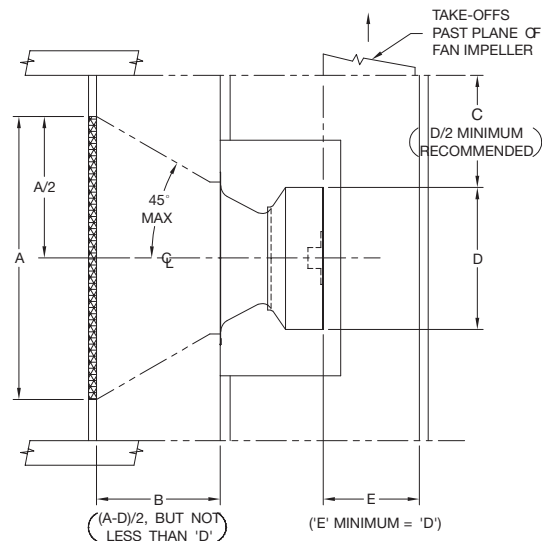

Figure 2. Flow Baffle and Vortex Spin Breaker Location

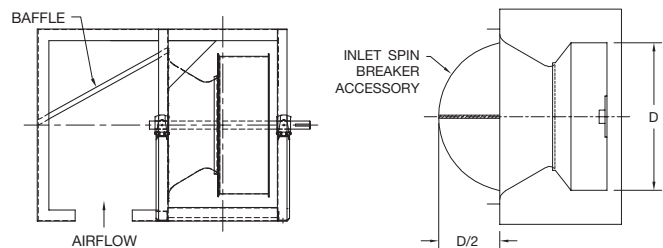
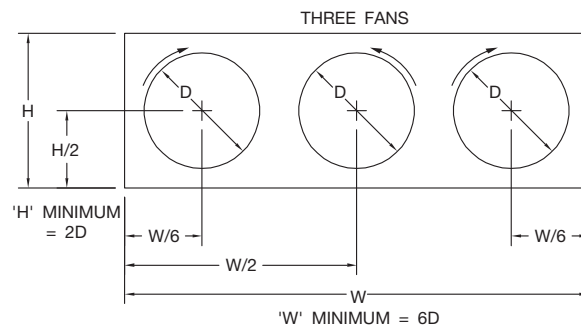
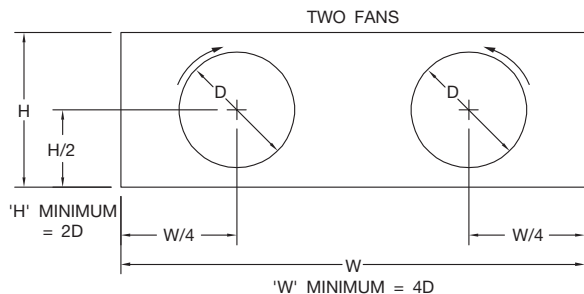

Figure 3. Location of Counter-Rotating Fans



NOTE: 'D' = Wheel diameter



# Twin City Fan Companies, Ltd.

Designers & Manufacturers of Air Moving Equipment

5959 Trenton Lane · Minneapolis, MN 55442-3237

Phone (763) 551-7600 · Fax (763) 551-7601 · www.twincityfan.com

