



# ENGINEERING DATA

Aerovent • TC Ventco • Fiber-Aire • Twin City Fan & Blower • TC Axial • Clarage

## Sealing of Fan Housings

### Introduction

A variety of options are offered by fan manufacturers to seal fan housings. Sealing the housing is important for several reasons:

1. Leakage is a waste of the energy supplied to the fan. Work is done to move the air, but the air does not arrive at its intended destination.
2. Depending on the composition of the airstream, contaminated air can pose an environmental or safety hazard.

3. Leakage of hot or contaminated air can damage the fan bearings.
4. Leakage can result in noise. Sealing can help reduce noise in certain circumstances.

These, as well as site-specific factors should be considered when determining the degree to which the housing should be sealed. This document will discuss the degree of fan sealing, types of shaft seals, and the importance of common caulks and gaskets used for specific fan applications.

### Part 1 – Degree of Sealing

There are differing degrees to which a fan housing can be “sealed” or made of tight enough construction to confine the flow inside the fan housing and connected ductwork. This discussion will deal with three degrees of fan sealing which will be referred to as “high leakage,” “medium leakage,” and “low leakage.” These designations are arbitrary and there are no clear lines between the three. This paper will attempt to give general distinctions which will help the engineer make decisions on the degree to which he must provide fan sealing.

Several areas need to be considered when dealing with sealing a fan housing:

1. Welding or sealing of inlet and outlet flanges.
2. Tightness of connections on inlets and outlets, access doors, cover plates, funnels, and on all flanges.
3. Welding of all housing joints.
4. Sealing of all housing joints.
5. Tightness of any appurtenances which could potentially leak; for example, flex connectors, inlet vanes, or outlet dampers.
6. Tightness of the shaft penetration, usually solved with a shaft sealing device.

Each of these areas will be considered when discussing the above listed degrees of fan sealing.

#### “High Leakage” Fan Sealing

This type of fan sealing might typically be used in a commercial fan. A commercial fan would be a vent-set type or other general ventilation fan where the cost of the fan would be of much greater importance than leakage when in process. Usually this fan would provide airflow at a fairly low pressure and the process stream would not be corrosive or hazardous.

1. The flanges in this fan are normally not full welded. Some may be skip welded with caulking between the welds. Other possibilities are riveting or mechanical staking.

2. Generally, the tightness of connections is not too important. Inlets, for example, might have flex connections connected to an inlet collar with sheet metal screws.
3. Housing joints may be full welded on this type of fan, or a stitch weld or lockseam system may be used. When the scroll is stitch welded to the housing side, typically a lip is turned to lay flat on the housing side with notches cut in it to allow for rolling around the scroll shape. These notches give a good recess to place a stitch weld in, after which the rest of the lip is caulked to the housing side. In the lockseam housing a standing seam is formed in the scroll sheet which the side plate fits into. This standing seam is then either crimped or mechanically staked to the housing side.
4. Housing drains on this type of fan are not normally sealed in any manner.
5. The tightness of appurtenances used with this type of fan is not critical. Slip connections may be attached to the discharge with sheet metal screws. Bearings which are used in vanes or dampers would probably be powder metal bronze bushings which would provide little resistance to leakage.
6. The shaft penetration through the housing is normally not sealed. If it is, the shaft seal is of a design which does not seal tightly.

#### “Medium Leakage” Fan Sealing

This type of fan sealing is typically used in a heavier duty fan, but not necessarily a heavy process fan. In this case there would be some desire to confine the process stream to the fan housing and associated ductwork, possibly because the process stream is high temperature or corrosive. There would be more consideration given to sealing the housing and connected ducting and appurtenances but the fan could be far from leak tight.

1. If the fan is of lower pressure, the inlet and outlet flanges may be stitch welded and caulked between the welds. In fans of this type at higher operating pressures the flanges are normally full welded.

2. The tightness of connections is of greater importance than of fans in the "high leakage" category. Inlets and outlets are flanged and gasketed with appropriate materials. Access doors, cover plates, funnels and all other flanges are gasketed.
3. Housing joints are normally full welded.
4. Housing drains are typically pipe couplings which are plugged if not piped when the fan is in process.
5. Tightness of connections to appurtenances is of greater importance in this type of fan. Flex connectors are flanged and gasketed. Bearings in dampers might still be the bushing type, but some designers would choose to move to a packing arrangement at the damper shaft penetration, especially in higher pressure applications. At about 25" SP packing gland seals on the dampers are recommended.
6. The shaft penetration through the housing must be sealed, at least with a simple friction type shaft seal. At higher pressures or in applications where leakage becomes more critical, some designers would use a tighter shaft seal such as a lip type seal, a mechanical type seal, or a stuffing box (packing gland) type seal.

### **"Low Leakage" Fan Sealing**

This type of fan sealing is used when leakage of the process stream into the surrounding area is very undesirable. "Leak tight" and "gas tight" constructions would fall into this category. It should be mentioned at this point that there are no recognized definitions for these types of descriptions, so it is of extreme importance that the fan vendor and customer agree on allowable leakage. The degree of sealing is something that can be measured in the factory, but can change as conditions change in the field or in the process.

1. Inlet and outlet flanges on this type of fan must be con-

tinuously welded, and in the case of "leak tight" construction, welded continuously on both sides.

2. Tightness of connections is very important. In the case of inlet cone, access door and cover plates, high quality double gaskets might be considered. Spacing of bolts on flanges, cover plates, and access doors is also important: 3" to 4" centers on bolts for these items is a good rule of thumb.
3. Housing joints are continuously welded, and in the case of "leak tight" construction are welded continuously on both sides. In "leak tight" construction split housings are not acceptable.
4. Housing drains are pipe couplings with plugs.
5. Tightness of connections to appurtenances is again very important. Discharge and inlet connections are sometimes even pipe flanges to provide a machined flat gasketing surface. Dampers must use packing gland seals around shafts.
6. The tighter types of shaft seals are used, typically stuffing box type shaft seals, lip seals, or mechanical type shaft seals. In very critical applications a neutral purging gas might be piped to the shaft seal at a higher pressure than the fan working pressure. This makes the flow direction into the fan through the shaft seal. Sometimes thrust vanes are used on these fans to create negative pressure at the shaft penetration, providing flow in through the penetration, instead of out into the surrounding area.

### **Backplate Fins**

Finally, with any of the above listed types of sealing, fins may be used on the fan backplate. These fins act the same way as the fan blades, but draw air in through the shaft penetration. Leakage is then into the fan instead of out.

## Part 2 – Shaft Seals

Sealing the fan housing at the penetration for the rotating shaft is one of the more difficult tasks in sealing a fan housing. There are many types of shaft seals which provide different degrees of sealing. The following fan seals are some

of the more common types. They differ in the degree of sealing required, composition of the process stream, and shaft speed limitations.

### Friction Shaft Seal

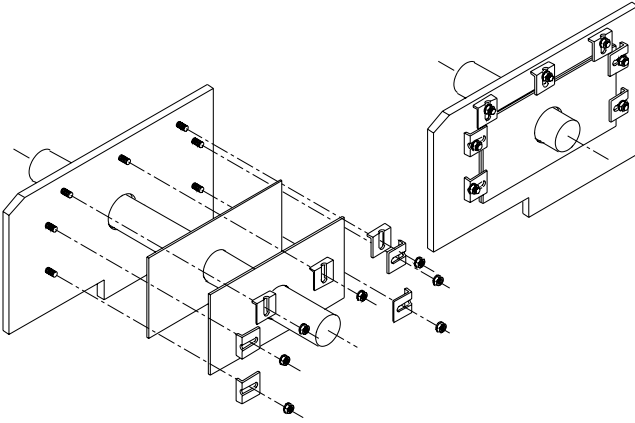

**Theory of Operation** — The friction shaft seal element is provided with a diameter smaller than the fan shaft. When the shaft seal outer plate compresses it against the fan housing, the sealing action is provided by the friction fit of the seal to the fan shaft.

#### Operating Limits:

**Temperature:** 1000°F seal element limit. Seal retains resiliency over a wide working temperature range.

**Pressure:** Seal provides little pressure sealing ability.

**Chemical Compatibility:** Seal element exhibits good chemical stability and neutrality. It is completely organic. It is not compatible with hydrofluoric and phosphoric acids or high concentrations of alkalis.

### V-Ring Type Seal

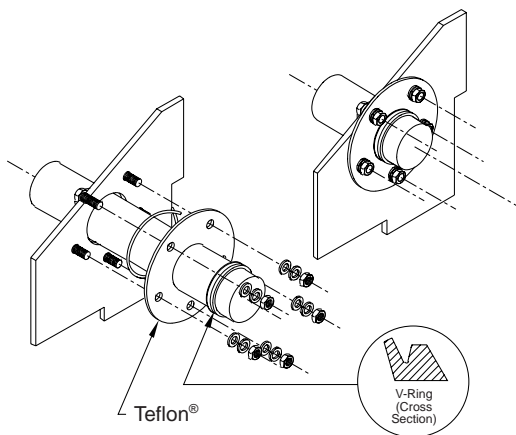

**Theory of Operation** — The axial type seal is compressed against the Teflon® wear plate. It seals when compressed to a specific amount. The friction fit of the V-ring seals the shaft.

#### Operating Limits:

**Temperature:** Standard seal material (Buna-N) -40 to 212°F Optional material (Viton) -9 to 300°F

**Pressure:** Although not designed as a pressure seal, the seal will provide moderate sealing in lower pressure applications (typically less than 25" water).

**Chemical Compatibility:** Seal element exhibits good chemical stability and neutrality within the operating range. For specific chemical compatibilities, refer to compatibility charts for Buna-N or Viton. Seals are not compatible with hydrofluoric or phosphoric acids or high concentration of alkalis.

## Double Lip Type Seal

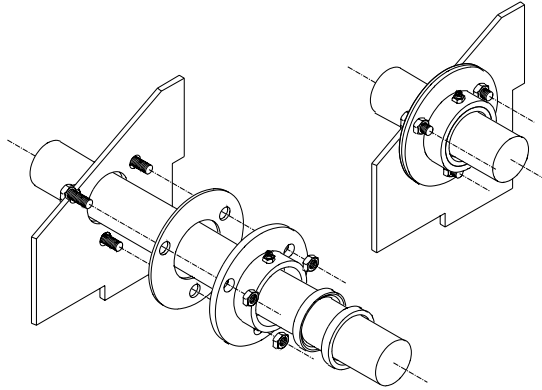

**Theory of Operation** — The sealing action is provided by two lip type seals placed back to front with in a seal housing with a layer of grease between them. The grease reservoir may be maintained using the grease fitting in the seal housing. The contact is between the seal inner lip and the circumference of the fan shaft.

### Operating Limits:

Temperature: Standard seal material (Buna-N) -40 to 212°F Optional material (Viton) -9 to 300°F

Pressure: The seal will provide fairly good sealing in lower pressure applications (typically less than 25" water).

Shaft Speeds: The seal is suitable for shaft speeds corresponding to a linear surface speed of 3200 FPM (ranges from greater than 5000 RPM for a  $\frac{7}{8}$  shaft to approximately 2200 RPM for a  $\frac{5}{16}$  shaft).

Chemical Compatibility: Seal element exhibits good chemical stability and neutrality within the operating range. For specific chemical compatibilities, refer to compatibility charts for Buna-N or Viton. Seals are not compatible with hydrofluoric or phosphoric acids or high concentration of alkalis.

## RP Mechanical Shaft Seal

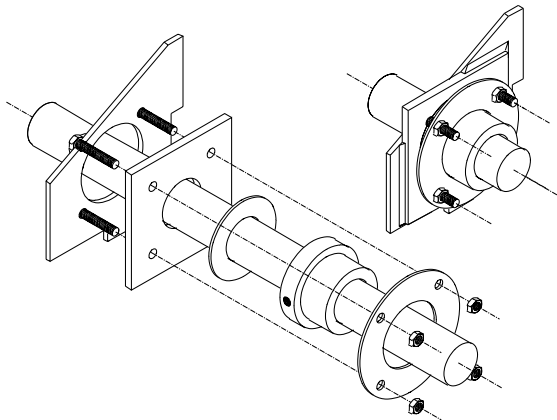

**Theory of Operation** — The sealing action occurs within the RP mechanical shaft seal. Internally the seal is held to the fan shaft by driving rings which grip the shaft. These in turn rotate other internal seal parts which provide the fan gas seal between rotating and stationary faces. The function of the mounting plate is simply to provide a firm mounting base for the seal. The outside mounting plate seats the mechanical shaft seal against the mounting plate with a Teflon<sup>®</sup> shaft seal ring to provide sealing of the entire assembly.

### Operating Limits:

Temperature: Standard seal material -10 to 300°F.

Pressure: Depending on gases being conveyed by fan, almost unlimited. Very high pressures may be effectively sealed.

Shaft Speeds: To 3600 RPM

Chemical Compatibility: A wide variety of gases may be handled, due to the wide variety of materials which can be used for the seal casing and internal elements.

## Stuffing Box Type Seal

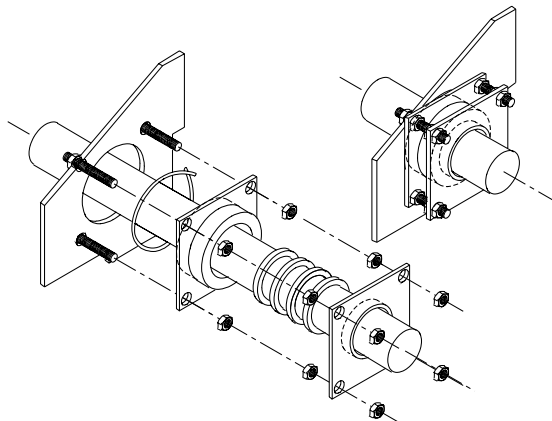

**Theory of Operation** — The stuffing box is sealed to the fan housing with PTFE joint sealant for a gasketing material. The packing materials are two flexible graphite split rings sandwiched between two carbon yarn anti-extrusion rings. The outside hex nuts force the outside packing plate into the stuffing box, expanding the graphite rings to provide a leak tight seal.

### Operating Limits:

**Temperature:** Dependent on the gas being moved.  
Can exceed the temperature limitations of most fan materials.

**Pressure:** Can provide excellent sealing performance at pressures exceeding those a single stage centrifugal can provide.

**Chemical Compatibility:** Seal element exhibits excellent chemical stability and neutrality, even at high temperatures.

## Stuffing Box Type Seal With Gas Purge

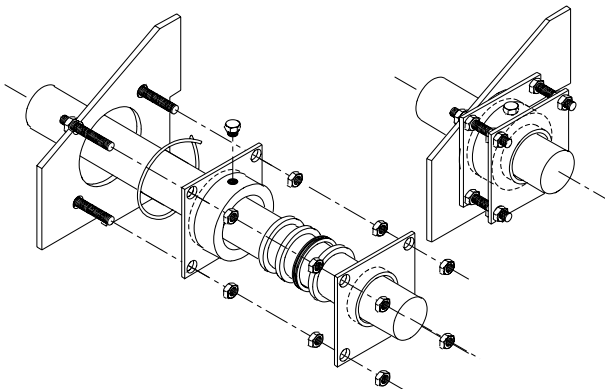

**Theory of Operation** — The stuffing box is sealed to the fan housing with PTFE joint sealant for a gasketing material. The packing materials are a flexible graphite split ring and a lantern ring sandwiched between two carbon yarn anti-extrusion rings. The outside hex nuts force the outside packing plate into the stuffing box, expanding the graphite rings to provide a leak tight seal. A pressure purge tap is provided to insure that all leakage will be the purge gas.

### Operating Limits:

**Temperature:** Dependent on the gas being moved.  
Can exceed the temperature limitations of most fan materials.

**Pressure:** Can provide excellent sealing performance at pressures exceeding those a single stage centrifugal can provide.

**Chemical Compatibility:** Seal element exhibits excellent chemical stability and neutrality, even at high temperatures.

Table 1. Seals

SEAL TYPE	RELATIVE COST	MAINTENANCE & REPLACEMENT	ALIGNMENT TOLERANCE
Friction Shaft Seal	Low	1	Not Critical
V-Ring Shaft Seal	Low	2	Not Critical
Double-Lip Shaft Seal	Medium	3	Fairly Critical, Based on Shaft Speed
RP Mechanical Shaft Seal	Medium	4	Not Critical
Stuffing Box Shaft Seal	High	5	Not Critical, Packing Elements Take Up Gaps
Stuffing Box Shaft Seal With Gas Purge	High	5	Not Critical, Packing Elements Take Up Gap

1. Shaft seal elements can be provided as split so the outer plate can be loosened, the new element can be placed, and the outer plate can be retightened.
2. Spare elements are sometimes installed on the shaft at assembly. The old element can be cut off and the spare element pushed into place. If this is not done, disassembly of the equipment is sometimes necessary to replace the V-ring element.
3. The seal must be regreased periodically to maintain the grease barrier. If the lip seals need to be replaced, there are seals that are split and held to the shaft by a band spring which can be used for replacement.
4. For replacement, the seal must be removed, all internal components replaced, and the seal then reinstalled. This usually requires disassembly of the equipment.
5. Occasionally the packing plate will have to be tightened down on the the elements to maintain sealing. The seal elements can be replaced when necessary.

### Part 3 – Gaskets and Caulk

Gaskets and caulk are an important part of the sealing of fans. Table 2 summarizes the common types of caulks and gaskets that are used in fan applications.

Table 2. Gaskets and Caulk

APPLICATION	SEALANT, CAULK OR GASKET TYPE	TYPE	TEMPERATURE RANGE	FAN APPLICATION TYPE
STANDARD & SPECIAL COATING FANS	STYRENE-BUTADIENE RUBBER	Caulk	300°F Max.	Standard Temperature
	STYRENE-BUTADIENE RUBBER	Gasket	300°F Max.	Standard Temperature
	CLOSED CELL NEOPRENE (FOAM)	Gasket	300°F Max.	Inlet & Outlet Accessories, Inlet Funnels
	ACRYLIC LATEX	Caulk	-30 to 180°F	Fans With Heresite or Air-Dried Phenolic Finishes
	RED SILICONE	Gasket	301 to 600°F	High Temperature Applications
	TREATED GLASS TAPE	Gasket	301 to 1000°F	High Temperature Applications Chemically Treated to Add Abrasion Resistance
STAINLESS STEEL & ALUMINUM FANS	CLEAR SILICONE	Caulk	500°F Max.	Aluminum & Stainless Steel Fan Seams
	CLOSED CELL NEOPRENE (FOAM)	Gasket	300°F Max.	Aluminum & Stainless Steel Fan Mating Surfaces
	CERAMIC FIBER ADHESIVE PUTTY	Gasket	-300 to 2300°F	Stainless Steel High Temperature Applications
	TREATED GLASS TAPE	Gasket	301 to 1000°F	Stainless Steel High Temperature Applications. Chemically Treated to Add Abrasion Resistance
AUTOMOTIVE	STYRENE-BUTADIENE RUBBER	Caulk	300°F Max.	Standard Temperature
	STYRENE-BUTADIENE RUBBER	Gasket	300°F Max.	Standard Temperature
	CLOSED CELL NEOPRENE (FOAM)	Gasket	300°F Max.	Inlet & Outlet Accessories, Inlet Funnels
	CERAMIC FIBER ADHESIVE PUTTY	Gasket	-300 to 2300°F	High Temperature Applications. Applied as a Putty, Dries to be Used as a Gasket.
	TREATED GLASS TAPE	Gasket	301 to 1000°F	High Temperature Applications Chemically Treated to Add Abrasion Resistance
	ACRYLIC LATEX	Caulk	-30 to 180°F	Fans With Heresite or Air-Dried Phenolic Finishes
	EMBOSSSED VINYL EDGE TRIM	Gasket	-20 to 160°F	Doors on Swing-out or Clamshell Design Fans
FOOD GRADE	GRAY SILICONE	Gasket	500°F Max.	Doors on Swing-out or Clamshell Design Fans
	CLEAR SILICONE	Caulk	500°F Max.	
	WHITE SILICONE	Gasket	-80 to 500°F	
	COMPRESSIBLE PTFE	Gasket	600°F Max.	
	WHITE NEOPRENE	Gasket	190°F Max.	
SPECIAL APPLICATIONS	WHITE NITRILE	Gasket	200°F Max.	
	EMBOSSSED VINYL EDGE TRIM	Gasket	-20 to 160°F	Doors on Swing-out or Clamshell Design Fans
	GRAY SILICONE	Gasket	500°F Max.	Doors on Swing-out or Clamshell Design Fans
	COMPRESSIBLE PTFE	Gasket	600°F Max.	"Low Leakage" Fans
	SILICONE SHEET	Gasket	500°F Max.	

## Conclusion

Sealing a fan is important for many reasons. Leakage can cause undue wear and damage, cause harm to personnel or the environment, be noisy, or waste energy and money. Fan

manufacturers offer many options for sealing fan housings to increase levels of comfort and safety. Even when the fan represents a small first cost, improved sealing of the fan may result in savings over the life of the fan.